

# **PRIME-AIRE**

LABORATORY  
FUME HOODS

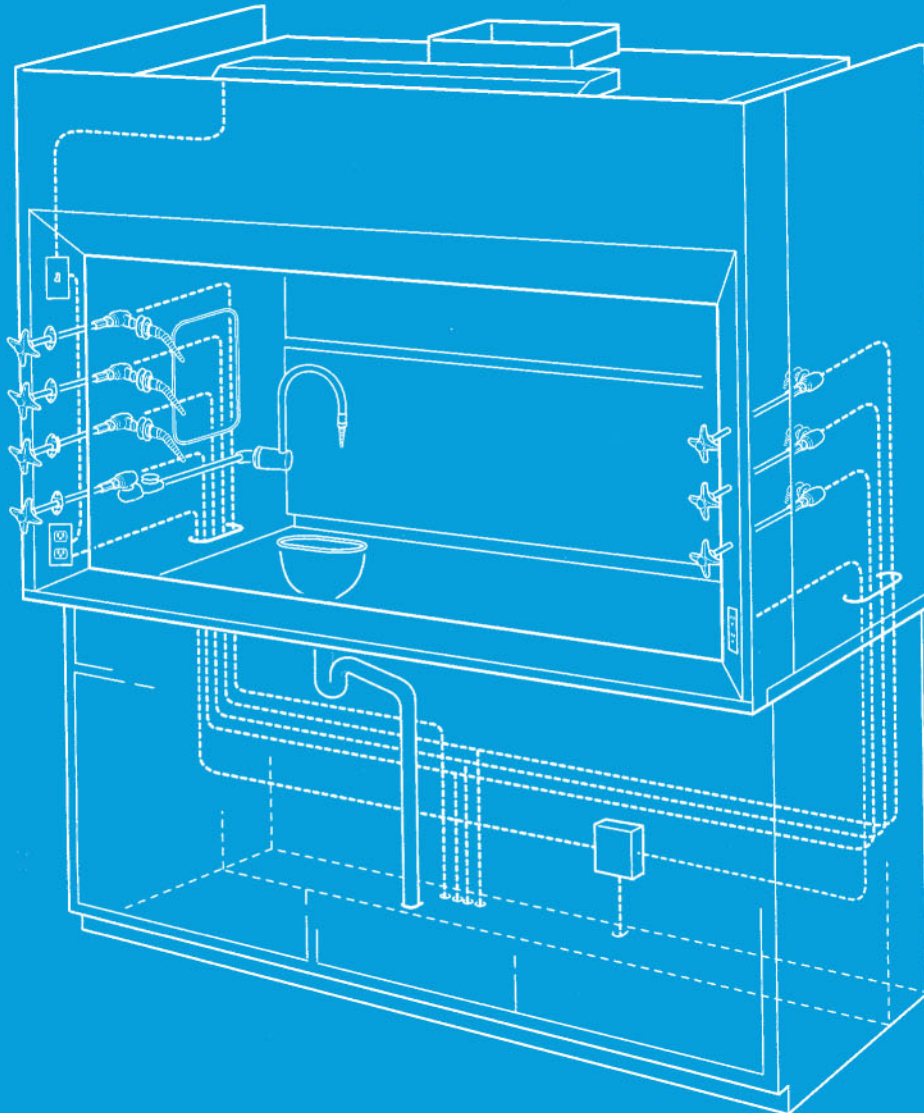

 **WOODWORK  
INSTITUTE**

## Airfoil

ADA Fume Hoods.....	12	Demonstration Fume Hood.....	22
ADA Fume Hood Assemblies.....	13	Drains.....	30
Add Air Fume Hoods.....	10	Electrical Fixtures.....	29
Add Air Fume Hood Assemblies.....	11	Filler Panels.....	26
Bypass Fume Hoods.....	6	Filters.....	32
Bypass Fume Hood Assemblies.....	7	Fire Extinguishers.....	31
Low Bench Fume Hoods.....	18	Flow Patterns.....	3
Low Bench Fume Hood Assemblies.....	19	Introduction.....	2
Perchloric Acid Fume Hoods.....	16	Lattice Assemblies.....	32
Perchloric Acid Fume Hood Assemblies.....	17	Local Exhaust.....	33
Radio Isotope Fume Hoods.....	14	Material Options.....	31
Radio Isotope Fume Hood Assemblies.....	15	Planning.....	4
Variable Volume Fume Hoods.....	8	Plumbing Rough-In.....	35
Variable Volume Fume Hood Assemblies.....	9	Portable Fume Hood.....	23
Walk-In Fume Hoods.....	18	Sash Options.....	27
Walk-In Fume Hood Assemblies.....	19	Service Fixtures.....	28
Alarms.....	28	Sinks.....	30
Anemometer.....	32	Smoke.....	32
Baffle Options.....	31	Specifications.....	36
Base Cabinets.....	26	Spray Booth.....	24-25
Baths.....	30	Thin Wall Fume Hood.....	20
Blowers.....	33-34	Thin Wall Fume Hood Assemblies.....	21
Canopy Hoods.....	26	Transitions.....	33
Ceiling Enclosures.....	27	Traps.....	30
Countertops.....	29	Vent Kits.....	31
Definitions.....	38	Wash Down.....	33
		Y Branches.....	33

**GENERAL** – *PRIME Industries* offers the most wanted, highly rated accessory items in faucets, polypropylene traps, and now the new LABORATORY FUME HOOD LINE: *PRIME-AIRE™* by *PRIME*. Over 50 years of experience, combined with state of the art engineering and testing facilities, provide you with a Fume Hood unsurpassed in quality and performance.

**TESTING** – Safety should be the number one concern when choosing a Fume Hood. That is why *PRIME-AIRE™* tests and certifies each style Fume Hood in accordance with the current ASHRAE method of testing performance of laboratory Fume Hoods.

The ASHRAE 110 test procedure is an industry standard, recognized by SEFA and the American Conference of Governmental Industrial Hygienists, for safe Fume Hood performance.

Our test facility is available for you to witness the ASHRAE test procedure or to test special designs. To make arrangements to visit our test facility, contact your local *PRIME-AIRE™* Representative.

**DESIGN** – The design of the *PRIME-AIRE™* Fume Hood provides you with maximum safety at minimum cost.

Incorporating standard options, such as combination sashes and sash stops, allows you to maintain face velocities while exhausting less air. Hence, the *PRIME-AIRE™* Fume Hood costs less to operate than other conventional units.

**REFERENCES** – The American Industrial Hygiene Association, The American Conferences of Governmental Industrial Hygienists and the American Society of Heating, Refrigerating and Air-Conditioning Engineers have all published guidelines on Fume Hood face velocities and operating procedures.

Because the performance of a Fume Hood is greatly affected by the surrounding conditions, the recommendations in this catalog are based on normal or average conditions. For recommendations on ideal or extreme conditions, the guidelines published by the above referenced agencies should be followed.

**SPECIFICATIONS** – *PRIME-AIRE™* Fume Hoods are manufactured in strict accordance with the specifications shown in this catalog. However, continuous testing and research may result in design and specification changes without advance notice.

---

## THE *PRIME* COMMITMENT TO EXCELLENCE in all we do...for all we serve.

Back in 1973, when *PRIME* Industries was established as manufacturers and fabricators of Epoxy Resin countertops and accessories, several critical decisions were made. They proved to be the fundamental reason for a growth curve which, by anyone's standards, is an outstanding success.

By far, the most important of these decisions was drawn from the most proven business principals: An unswerving commitment to giving our clients the finest quality products at the most reasonable price consistent with a professional level of service

During more than 30 years of uninterrupted growth, *PRIME* has steadily defined the discipline of anticipating and serving our customer's needs, both present and future.

It is increasingly apparent that there is a growing demand for specialization in the marketplace for laboratory accessories and components. In response, we are proud to introduce our newly expanded accessory package which has been specifically designed as "a single *PRIME* source" for the agent, thus freeing up his or her time to concentrate on selling rather than shopping.

We look forward to continuing to supply your laboratory requirements, and stand ready to help with any particular situation. Excellent service is part of our commitment to you. Your business is important to us.

## Airfoil Bypass Hoods

The Airfoil Bypass Hoods have a double bypass to provide constant exhaust volume and limit changes in face velocity.

The upper bypass functions automatically with the raising and lowering of the sash. The lower bypass provides a continuous air sweep of the work surface.

When hood top enclosures are used, a bypass grille must be specified.

*Sash Closed*

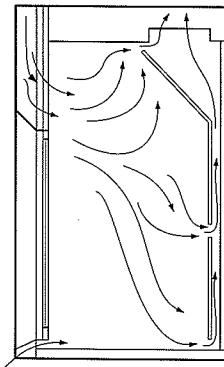

*Sash Open*

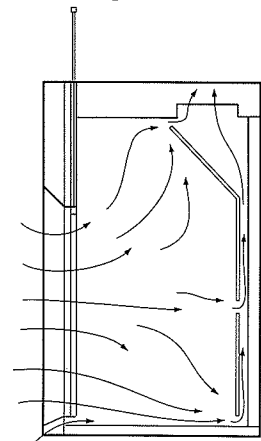

## Airfoil Variable Air Volume Hoods

The Variable Air Volume (VAV) Hoods are designed to be used with exhaust control systems provided by other manufacturers.

In lieu of an upper bypass the VAV Hood has a lintel which restricts the air intake of the Hood to the sash opening and lower bypass.

The commercially available exhaust control system will detect the movement of the sash and adjust the volume of air required to maintain a constant face velocity.

Factory mounting of the exhaust controls is available when specified.

*Sash Closed*

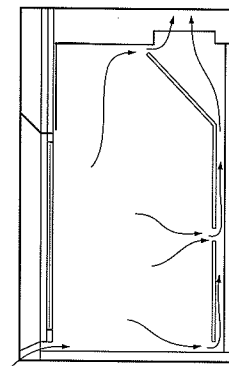

*Sash Open*

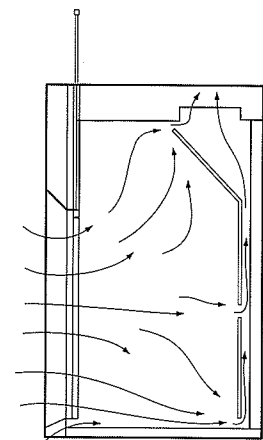

## Airfoil Add Air Hoods

The Add Air Hoods provide up to 70% of the Hood exhaust requirements. With a bypass similar to the Airfoil Bypass Hood, outside air is introduced through the add air plenum, thus minimizing the amount of conditioned room air required.

When outside temperatures are extreme, it may be necessary to temper the incoming air.

*Sash Closed*

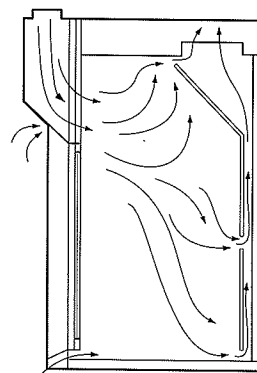

*Sash Open*

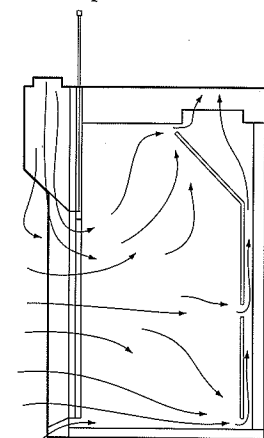

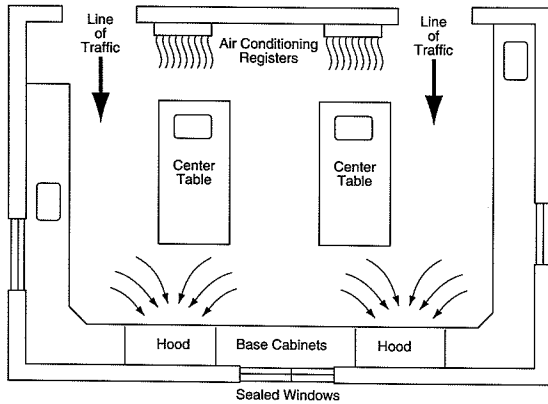

Figure 1 Good Locations

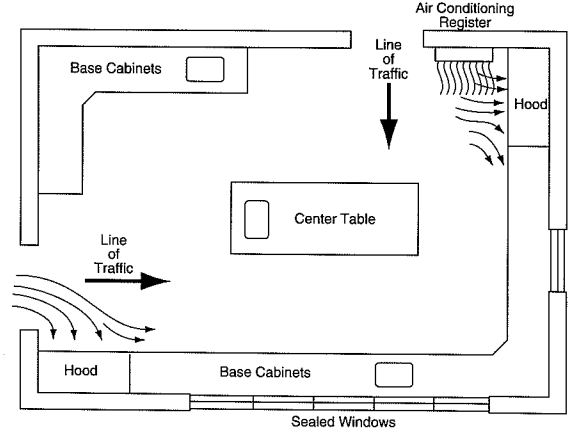

Figure 2 Poor Locations

## Fume Hood Selection

There are two main factors to consider when selecting a Fume Hood style.

First consider the type of work being performed in the Hood. The use of perchloric acid or radioactive materials require a Fume Hood specifically designed for these materials. Large apparatus or complex set-ups may require the use of a low bench or walk-in Fume Hood to accommodate the space requirements.

The second consideration in selecting a Fume Hood style is the air consumption of the hood. Operation of a Fume Hood requires a relatively large volume of room air.

If you determine that the amount of air being supplied to the room is adequate to accommodate the exhaust volume of the Fume Hood the ByPass style Fume Hood would be an excellent choice.

If there is not enough supply air available, the Add Air style may be the right choice.

The Variable Air Volume style Fume Hood is designed to be used with an adjustable damper system in the ductwork. The use of this Hood will, when used in conjunction with a VAV control system, drastically reduce the total amount of air consumed. This makes the Variable Air Volume style Hood a good choice when trying to reduce air consumption for energy cost savings or when there simply is not enough available supply air.

For more information see "Flow Patterns" on Page 3.

## Fume Hood Locations

Location of the Fume Hood is of prime importance, since a variety of conditions will affect the performance of the Hood.

When selecting a location for the Fume Hood, operator convenience, work flow and exhaust duct locations should all be considered. In addition, an attempt should be made to keep the hood away from the line of traffic. It is both inconvenient and dangerous to install a Fume Hood so that the operator is forced to work in the line of traffic movement.

The presence of cross-drafts will adversely affect the performance of the Fume Hood. For this reason it is a good idea not to locate the Fume Hood near open doors and windows. High velocity air diffusers located directly in front of the Fume Hood could actually draw fumes out of the Hood and into the room. Although there is no single preferred method for delivery of make up air, it is a good idea to locate the Fume Hood as far from the air diffuser as possible so that the air first sweeps through the laboratory working area and then into the Fume Hood.

## Fume Hood Velocity Selection

Selection of the Fume Hood face velocity should be directly related to the location of the Fume Hood. A Fume Hood in a good location, as shown in Fig. 1, should operate properly at a face velocity of 75 FPM. A poorly located Fume Hood, as shown in Fig. 2, may require a face velocity of 125 FPM to maintain proper performance.

Since most fume hood installations require some type of location compromise, a face velocity of 100 FPM is usually the norm. Fume Hoods with a high heat source may require slightly higher face velocities.

OSHA calls for, but does not require, a face velocity of 150 FPM for Fume Hoods used with any of the 13 carcinogens listed in OSHA 1910.1003 et seq. (OSHA 1978). Studies have shown that hoods operated at face velocities of 150 FPM and greater often perform poorer than if operated at a lower face velocity, due to disruptive air turbulence at the perimeter of the Hood opening and in the wake of objects placed inside the work area of the Hood.

## Fume Hood Blowers & Ductwork

The blower and ductwork control the amount of air moving through the Fume Hood. For this reason it is extremely important that they be installed and maintained properly.

By using the chart on page 34, you can choose the correct blower for the Fume Hood you have selected.

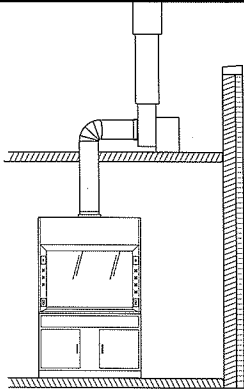

Figure 3

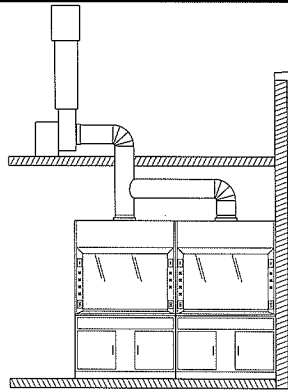

Figure 4

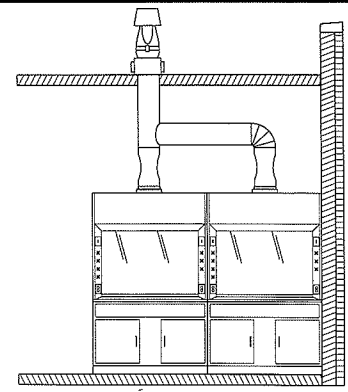

Figure 5

Whenever possible exhaust blowers should be located on the roof of the building. This will insure that the ductwork inside the building will remain under negative pressure preventing leakage of contaminated air into occupied spaces.

Supply or add-air blowers may be located on the rooftop, side ledge, warehouse space or any other suitable location. The prime concern when locating the add-air blower is that it remain far enough away from other exhaust outlets to avoid cross-contamination. The other consideration is the temperature of the incoming air. Locating the add-air blower in an area of semi-conditioned air, like a warehouse, may provide a more comfortable work area at the front of the Hood, while avoiding the need to condition the supply air.

Add-Air Fume Hoods require the use of both an exhaust blower and a supply blower. It is recommended that both blowers be connected to a single on/off switch. This will avoid the possibility of room contamination by turning on only the supply blower.

When using high concentrations of aerosols, solvents or other flammable vapors inside the fume hood, an exhaust blower with a non-sparking wheel and explosion-proof motor may have to be used.

The duct material should be resistant to the materials used in the Fume Hood. PVC, coated steel and stainless steel are all common choices. The ductwork should be installed with as few bends as possible and have air tight joints.

Ducts are excellent conductors of sound. Anchoring the ductwork securely to the building structure and sizing the ductwork so as not to exceed velocities in excess of 2000 FPM will help to reduce duct noise.

The exhaust discharge should be located at least 10' above the roof structure and have a zero pressure weather cap. Covered weather caps that increase static pressure and interfere with the flow of discharged air are not recommended.

As a rule, each Fume Hood should be exhausted by its own exhaust blower, as shown in Figure 3. When multiple Hoods are manifolded to a single exhaust blower, as shown in figure 4, imbalance in the exhaust airflow can occur as Hoods are turned on and off. To overcome this situation, all Hoods could be

turned on and off together. However, this may result in an unsatisfactory arrangement from the standpoint of energy efficiency.

Multiple Hoods which are controlled by a variable air volume (VAV) control system may be manifolded to a single exhaust blower. The VAV controls maintain the proper air balance and provide excellent energy efficiency, by reducing the amount of air being exhausted when the Hood is not in use.

Care should be taken in the design of the VAV system. The air being supplied to the laboratory must also be variable to meet the changing exhaust volume of the Fume Hoods. If not, over pressurization of the laboratory could occur causing contamination of adjacent areas.

Because the exhaust volume of the VAV system can vary greatly, it is a good idea to select an exhaust blower with some type of air bypass, as shown in Figure 5. This will keep the fan motor from overloading and maintain an acceptable stack velocity.

Fume Hood blowers and ductwork systems should be included in the maintenance schedule. Dust and other contaminants collected on the blades of the fan can greatly reduce its capacity. Blowlers should be placed so that they are accessible for periodic cleaning. Periodic examination of the ductwork should also be made to detect any loose joints or porosity due to corrosion.

## Fume Hood Operation

A fume hood must be properly installed and operated in order to achieve optimum performance.

When using a Fume Hood, keep all apparatus at least 6" back from the face of the Hood. Do not put your head in the Hood when contaminants are being generated. Do not store chemicals or apparatus in the hood. Following these guidelines will help insure proper performance of the Fume Hood.

OSHA requires laboratories, where hazardous chemicals are used, to develop and carry out a written chemical hygiene plan. This plan should include provisions for monitoring fume hoods for proper performance, as well as periodic performance testing of the Fume Hoods. The Fume Hood air flow monitors, anemometer and smoke bombs shown on page 28 and 32 will help you meet the requirements.

# Airfoil Bypass Fume Hoods

**PRIME-AIRE™**

Continuous air flow across the work surface of the Airfoil Bypass Fume Hood exhausts potentially hazardous vapors safely away from the work environment, even with the sash closed!

The Airfoil Bypass Fume Hood features an internal bypass opening located above the sash allowing for a constant exhaust volume while maintaining the face velocity. In operation, the bypass works automatically, in conjunction with the hood sash. The bypass adjustment is made as the sash is opened and closed creating a relatively constant face velocity regardless of sash position.

## Design

The Bypass Fume Hood comes equipped with a full view sash providing an unobstructed view of the Hood interior work area. The sash, a glazed 7/32" thick laminated safety glass is provided with a full width flush pull. A counterweight provides for one finger operation of the sash at any position.

The entrance of the Hood is framed with inward-angled members. This angled frame works to minimize turbulence and provide smooth movement of air into the Hood, resulting in a more efficient operation of the Fume Hood at face velocities ranging from 60 to 150 FPM. A lower airfoil sash stop maintains a 1" space (below closed sash) that allows air to flow continuously across the work surface inside the Hood.

Double wall construction of the Hood superstructure allows for easy installation of service fixtures and routing of interior plumbing and electrical lines. The interior of the Airfoil Bypass Fume Hood is white "Resin-Chem." Removable access panels on both interior sides of the Hood are standard features. The exterior superstructure side panels are also removable for easy access to service fixtures and supply lines.

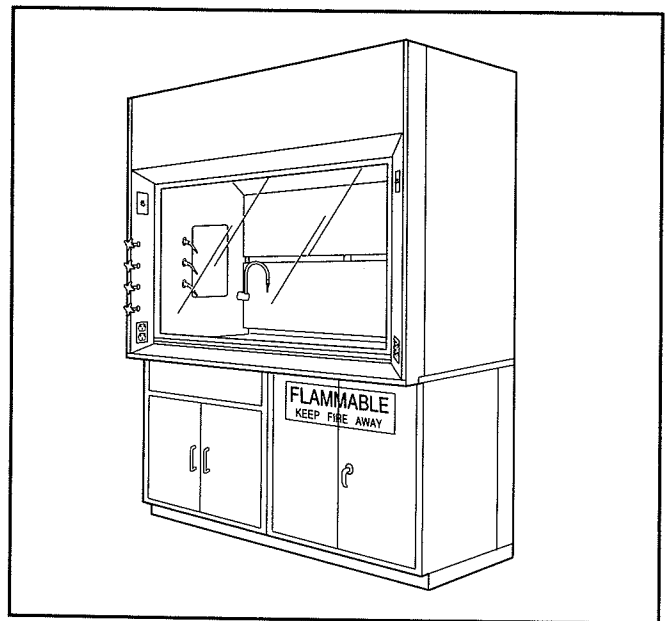

## Interior Lighting

A maximum width, two tube fluorescent light fixture, complete with tubes, is provided with the Airfoil Bypass Fume Hood. The light fixture is mounted above a sealed safety glass panel isolating it from corrosive fumes and hazardous vapors. Tube lights are easily replaced through the top front of the Fume Hood superstructure.

## Options

A variety of optional service fixtures are available from **PRIME-AIRE™** for installation in the Bypass Fume Hood. Our **PRIME-AIRE™** representatives work closely with customers in specifying the type of fixtures and electrical receptacles required.

Fume Hood Superstructures are available in widths from 47" to 96", including **PRIME-AIRE™**'s unique 82" and 84" wide models as shown below. Service and electrical fixtures shown are optional and must be ordered separately.

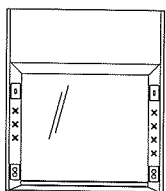

B-704 47"  
B-604 48"

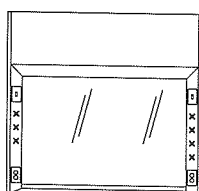

B-705 58"  
B-605 60"

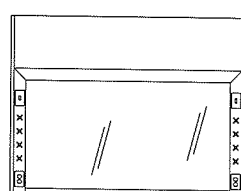

B-706 70"  
B-606 72"

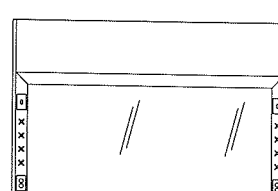

B-707 82"  
B-607 84"

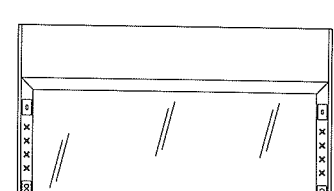

B-708 94"  
B-608 96"

## Airfoil Bypass Fume Hood Assemblies

The ten standard Fume Hood sizes are each available as a complete assembly.

Detailed information on base cabinets, countertops and service fixtures is shown on pages 26, 28 and 29.

The assembly for the 47"/48" and 58"/60" wide Hoods consists of a standard base cabinet, two LF35-7 filler

panels, dished epoxy resin countertop, F-400 3" x 6" epoxy resin cupsink, six F-100 service fixtures, F-110 cold water fixture, F-200 light switch, F-210 blower switch and two F-220 110V duplexes.

70"/72", 82"/84" and 94"/96" assemblies include all of the above along with a second base cabinet, cupsink and water fixture.

All service and electrical fixtures are furnished, but not installed.

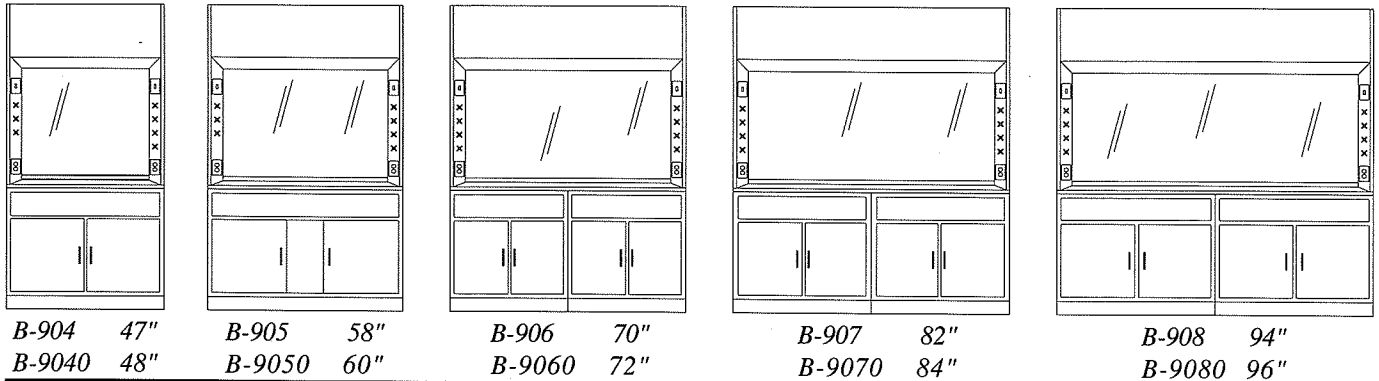

## Rough-in Details

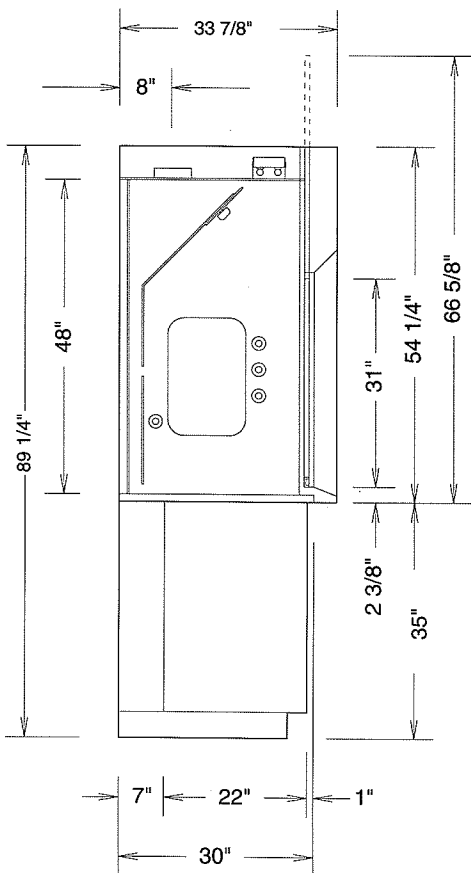

HOOD SIZE	COLLAR SIZE	75 FPM		100 FPM		125 FPM		150 FPM	
		CFM	S.P.	CFM	S.P.	CFM	S.P.	CFM	S.P.
47"/48"	6" x 12"	633/650	.21/.22	844/867	.37/.39	1055/1083	.58/.61	1266/1300	.83/.87
58"/60"	6" x 16"	817/850	.20/.21	1089/1133	.36/.38	1361/1417	.56/.59	1634/1700	.81/.85
70"/72"	6" x 20"	1016/1050	.21/.21	1355/1400	.38/.37	1694/1750	.56/.58	2033/2100	.81/.84
82"/84"	(2)6" x 12"	1212/1250	.19/.21	1616/1667	.35/.37	2020/2083	.60/.58	2492/2500	.85/.83
94"/96"	(2)6" x 12"	1417/1450	.23/.25	1889/1933	.42/.45	2361/2417	.65/.71	2834/2900	.93/1.02

The static pressures listed above are for the hoods only. An appropriate amount will have to be added to this figure to compensate for the pressure drop through the duct system. The total pressure drop through the hood and the duct system must be known to select the proper exhaust blower.

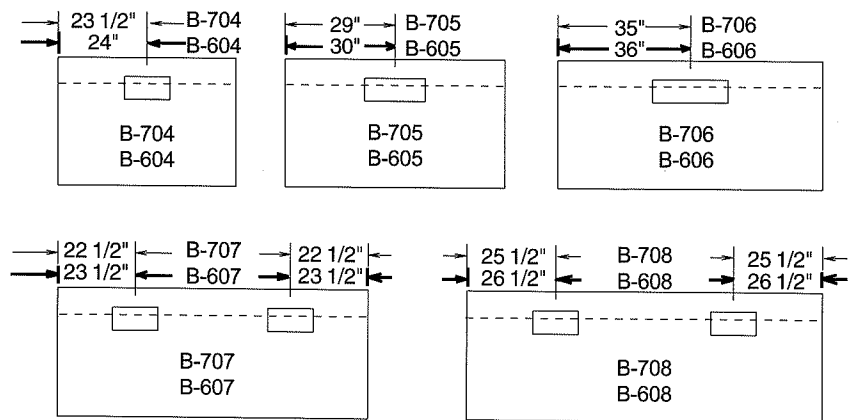

Duct collar locations are as shown above. The center line of each collar is 8" from the back of the hood. The area indicated by the dashed lines is designated for plumbing and electrical rough-ins. All rough-ins should be kept within 7" of the wall and 18" from the floor.



# Airfoil Variable Volume Fume Hoods

**PRIME-AIRE™**

The Variable Volume Fume Hood is specifically designed for use with exhaust control systems provided by other manufacturers that monitor and control the amount of air being exhausted from the Hood. The use of these devices will maintain a constant face velocity and greatly reduce the operating cost of the Fume Hood.

## Design

A lintel at the upper front of the superstructure restricts the Hood air intake to the front sash opening. By incorporating any one of a number of commercially available VAV controls, the exhaust volume of the Hood can be varied to maintain a specified face velocity regardless of sash position.

The full view sash provides a clear, unobstructed view of the work surface and when fully opened allows easy access to all areas of the Hood interior. The sash is counterweighted for easy up/down operation and is made of 7/32" laminated safety glass with a full width flush pull.

The lower airfoil acts as a sash stop designed to provide a 1" gap (with sash closed) allowing air to continuously sweep the countertop of the Fume Hood.

Double side wall Hood construction provides adequate space for mounting service fixtures. The interior "Resin-Chem" lining has removable access panels on either side providing easy access for installation and maintenance of service and electrical fixtures. Both exterior side panels of the Hood superstructure are also removable for access to lines.

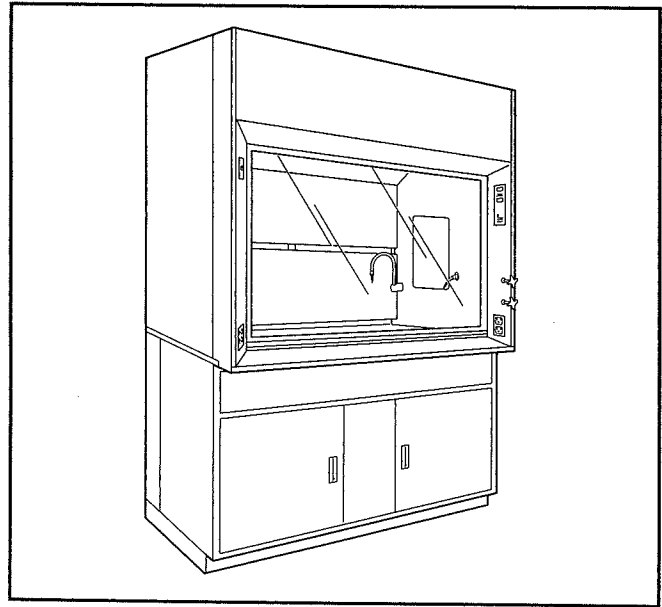

## Interior Lighting

A twin tube fluorescent light fixture provides illumination of the Hood's interior surfaces. The fixture is recessed into the interior Hood ceiling and protected behind a sealed safety glass panel away from hazardous vapors and corrosive fumes. Tubes (included with Hood purchase) are easily replaced from the outside of the Hood superstructure.

## Options

A variety of optional service fixtures are available from **PRIME-AIRE™** for installation in the Variable Volume Fume Hood. Mounting holes for fixtures and electrical receptacles are pre-cut and capped when fixtures are not required.

Fume Hood Superstructures are available in widths from 47" to 96", including **PRIME-AIRE™**'s unique 82" and 84" wide models as shown below. Service and electrical fixtures shown are optional and must be ordered separately.

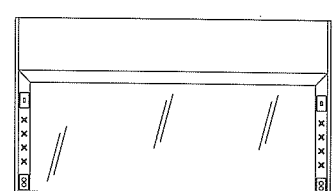
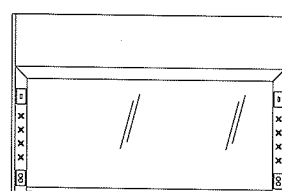
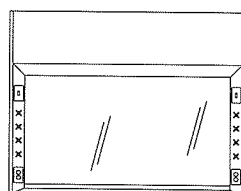
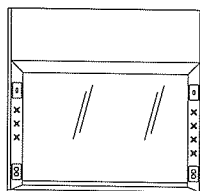
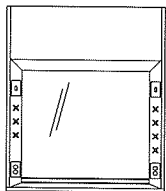

B-714 47"  
B-614 48"

B-715 58"  
B-615 60"

B-716 70"  
B-616 72"

B-717 82"  
B-617 84"

B-718 94"  
B-618 96"

# Airfoil Variable Volume Assemblies

**PRIME-AIRE™**

## Airfoil Variable Volume Assemblies

The ten standard Fume Hood sizes are each available as a complete assembly.

Detailed information on base cabinets, countertops and service fixtures is shown on pages 26, 28 and 29.

The assembly for the 47"/48" and 58"/60" wide Hoods consists of a standard base cabinet, two LF35-7 filler

panels, dished epoxy resin countertop, F-400 3" x 6" epoxy resin cupsink, six F-100 service fixtures, F-110 cold water fixture, F-200 light switch, F-210 blower switch and two F-220 110V duplexes.

70"/72", 82"/84" and 94"/96" assemblies include all of the above along with a second base cabinet, cupsink and water fixture.

All service and electrical fixtures are furnished, but not installed.

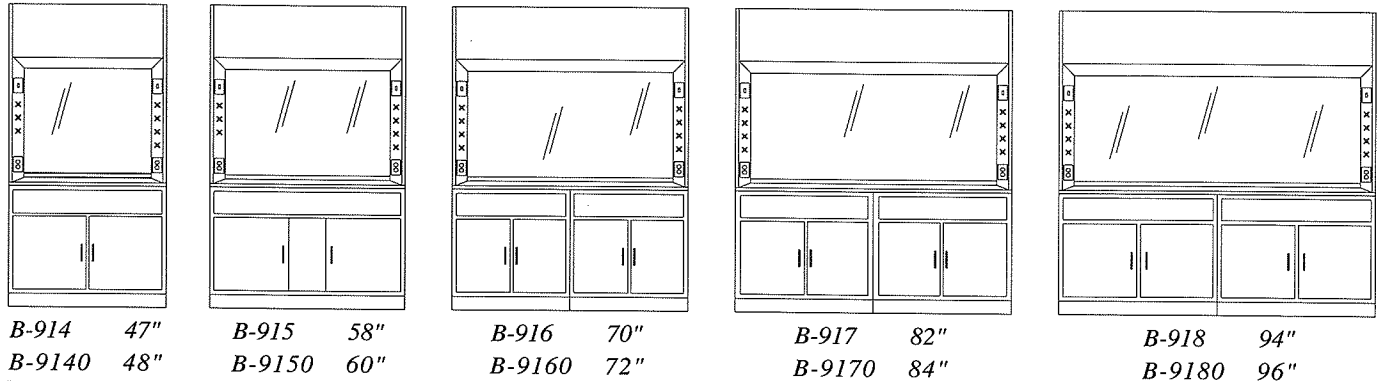

## Rough-in Details

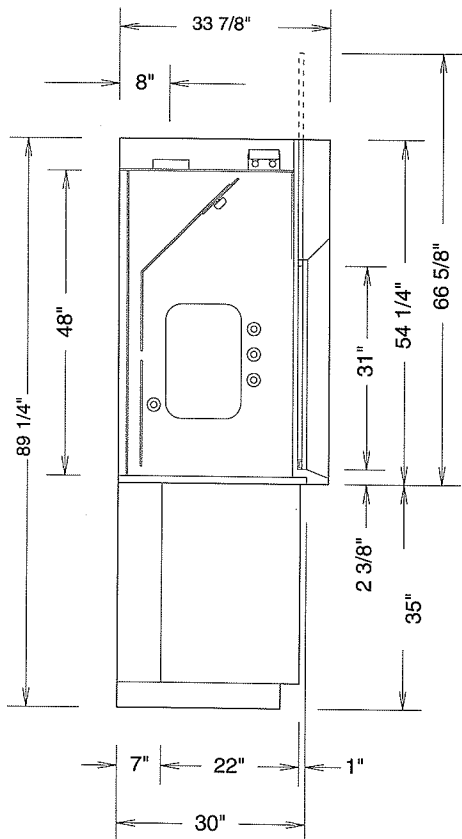

HOOD SIZE	COLLAR SIZE	75 FPM		100 FPM		125 FPM		150 FPM	
		CFM	S.P.	CFM	S.P.	CFM	S.P.	CFM	S.P.
47"/48"	6" x 12"	633/650	.21/.22	844/867	.37/.39	1055/1083	.58/.61	1266/1300	.83/.87
58"/60"	6" x 16"	817/850	.20/.21	1089/1133	.36/.38	1361/1417	.56/.59	1634/1700	.81/.85
70"/72"	6" x 20"	1016/1050	.21/.21	1355/1400	.38/.37	1694/1750	.56/.58	2033/2100	.81/.84
82"/84"	(2)6" x 12"	1212/1250	.19/.21	1616/1667	.35/.37	2020/2083	.60/.58	2492/2500	.85/.83
94"/96"	(2)6" x 12"	1417/1450	.23/.25	1889/1933	.42/.45	2361/2417	.65/.71	2834/2900	.93/1.02

The static pressures listed above are for the hoods only. An appropriate amount will have to be added to this figure to compensate for the pressure drop through the duct system. The total pressure drop through the hood and the duct system must be known to select the proper exhaust blower.

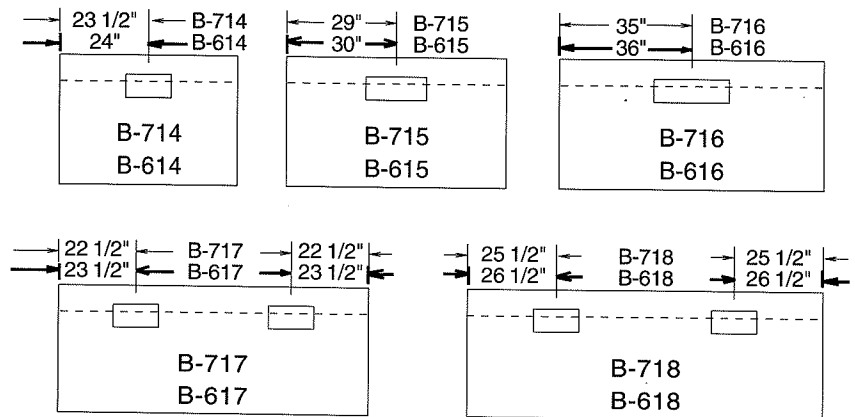

Duct collar locations are as shown above. The center line of each collar is 8" from the back of the hood. The area indicated by the dashed lines is designated for plumbing and electrical rough-ins. All rough-ins should be kept within 7" of the wall and 18" from the floor.

# Airfoil Add Air Fume Hoods

**PRIME-AIRE™**

The **PRIME-AIRE™** Airfoil Add Air Fume Hood provides added economy through the use of a front mount "add air plenum" that can supply up to 70 percent of the total Hood air volume requirement from an outside source.

## Design

The superstructure entrance of the Add Air Fume Hood is framed with inward angled members that minimize turbulence and provide smooth movement of air into the Hood. This design allows for efficient operation of the Fume Hood at face velocities ranging from 60 to 150 FPM. Additionally, the built-in bypass feature above the Hood sash works to maintain a relatively constant face velocity at any sash position.

The front mounted add air plenum of the Airfoil Add Air Fume Hood utilizes a series of diffusers and louvers to provide a uniform flow of supply air to the face of the Fume Hood. This uniform air flow allows for providing up to 70% of the overall air volume requirements of the Hood through the add air plenum.

As with other **PRIME-AIRE™** Fume Hoods, the Add Air Hood comes equipped with a full view laminated safety glass sash with a full width flush pull and counterweight for easy operation. A lower airfoil acts as sash stop that provides a 1" space for air to continuously flow into the Hood and across the work surface.

Double wall construction of the superstructure provides adequate space on both sides of the Hood for installation of service fixtures and routing of plumbing and electrical lines. The lining of the interior work area of the Hood is white Resin-Chem with removable interior access panels on both sides. Removable exterior side panels provide easy access to fixtures and their service lines.

Fume Hood Superstructures are available in widths from 47" to 96", including **PRIME-AIRE™**'s unique 82" and 84" wide models as shown below. Service and electrical fixtures shown are optional and must be ordered separately.

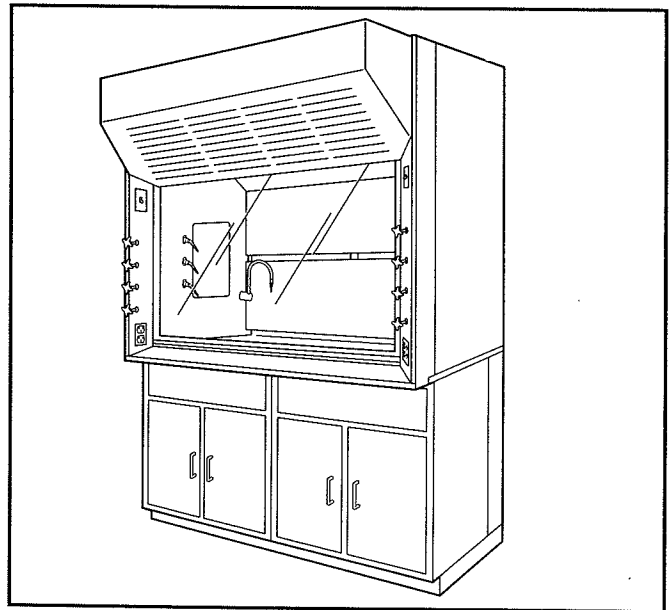

## Interior Lighting

The interior of the Add Air Fume Hood is brightly lit by a maximum width dual fluorescent tube light fixture. The fixture is mounted behind a sealed safety glass panel to isolate the fixture from corrosive fumes and flammable vapors. Replacement of fluorescent tubes is accomplished from the exterior top front of the Fume Hood superstructure.

## Options

Choose from the variety of optional service fixtures available from **PRIME-AIRE™**. Service fixture and electrical outlet types and locations are to be specified by the customer to fit each particular application. Mounting holes are provided in the superstructure for final on-site installation of optional equipment.

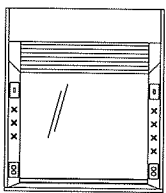

B-724 47"  
B-624 48"

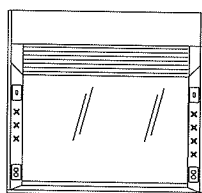

B-725 58"  
B-625 60"

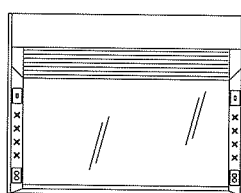

B-726 70"  
B-626 72"

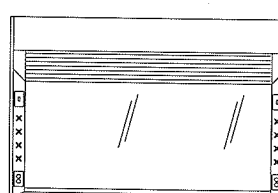

B-727 82"  
B-627 84"

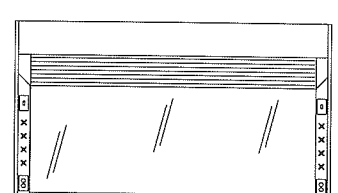

B-728 94"  
B-628 96"

## Airfoil Add Air Hood Assemblies

The ten standard Fume Hood sizes are each available as a complete assembly.

Detailed information on base cabinets, countertops and service fixtures is shown on pages 26, 28 and 29.

The assembly for the 47"/48" and 58"/60" wide Hoods consists of a standard base cabinet, two LF35-7 filler

panels, dished epoxy resin countertop, F-400 3" x 6" epoxy resin cupsink, six F-100 service fixtures, F-110 cold water fixture, F-200 light switch, F-210 blower switch and two F-220 110V duplexes.

70"/72", 82"/84" and 94"/96" assemblies include all of the above along with a second base cabinet, cupsink and water fixture.

All service and electrical fixtures are furnished, but not installed.

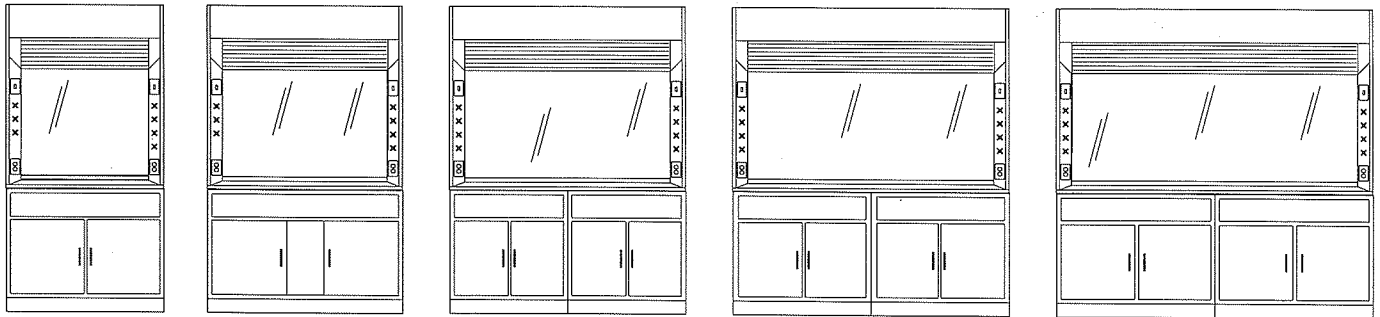

B-924 47"      B-925 58"      B-926 70"      B-927 82"      B-928 94"  
 B-9240 48"      B-9250 60"      B-9260 72"      B-9270 84"      B-9280 96"

## Rough-in Details

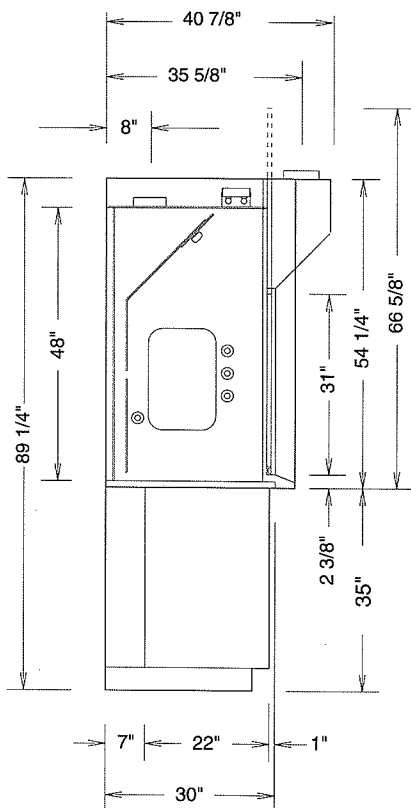

HOOD SIZE	COLLAR SIZE	75 FPM		100 FPM		125 FPM		150 FPM	
		CFM	S.P.	CFM	S.P.	CFM	S.P.	CFM	S.P.
47"/48"	EXH 6" x 12"	633/650	.21/.22	844/867	.37/.39	1055/1083	.58/.61	1266/1300	.83/.87
	SUP 6" x 12"	443/455	.16/.17	590/607	.29/.30	738/758	.46/.48	886/910	.66/.69
58"/60"	EXH 6" x 16"	817/850	.20/.21	1089/1133	.36/.38	1361/1417	.56/.59	1634/1700	.81/.85
	SUP 6" x 16"	572/595	.16/.17	762/793	.28/.29	953/992	.45/.47	1144/1190	.66/.69
70"/72"	EXH 6" x 20"	1016/1050	.21/.21	1355/1400	.38/.37	1694/1750	.56/.58	2033/2100	.81/.84
	SUP 6" x 20"	711/735	.16/.17	948/980	.30/.31	1186/1225	.44/.46	1423/1470	.65/.68
82"/84"	EXH (2) 6" x 12"	1212/1250	.19/.21	1616/1667	.35/.37	2020/2083	.60/.58	2492/2500	.85/.83
	SUP (2) 6" x 12"	848/875	.14/.15	1131/1167	.28/.29	1415/1458	.44/.46	1744/1750	.68/.71
94"/96"	EXH (2) 6" x 12"	1417/1450	.23/.25	1889/1933	.42/.45	2361/2417	.65/.71	2834/2900	.93/1.02
	SUP (2) 6" x 14"	992/1015	.16/.17	1322/1353	.30/.31	1652/1691	.47/.49	1984/2030	.68/.71

The static pressures listed above are for the hoods only. An appropriate amount will have to be added to this figure to compensate for the pressure drop through the duct system. The total pressure drop through the hood and the duct system must be known to select the proper exhaust blower. Supply figures are based on 70% add air.

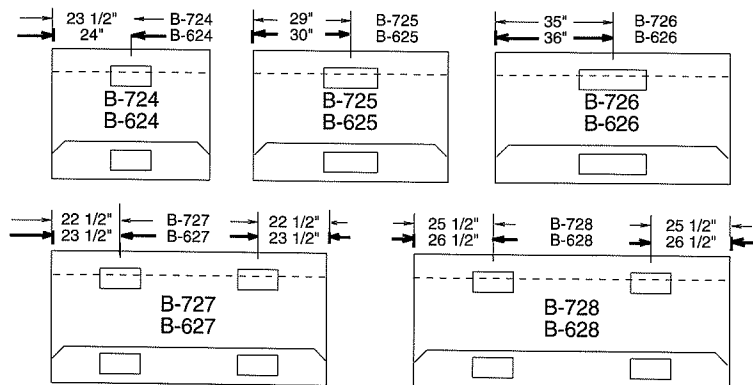

Duct collar locations are as shown above. The center line of each collar is 8" from the back of the hood. The center line of the supply duct is 35 5/8" from the back of the hood. The area indicated by the dashed lines is designated for plumbing and electrical rough-ins. All rough-ins should be kept within 7" of the wall and 18" from the floor.

# Airfoil ADA Fume Hoods

**PRIME-AIRE™**

*PRIME-AIRE™'s ADA Fume Hood is designed to meet the unique needs of wheelchair operators. The ADA Fume Hood delivers all the features and capabilities of our standard Fume Hood line with special accommodations built in to meet the specific requirements needed to provide a safe work site for wheelchair operators.*

## Design

The Americans with Disabilities Act (ADA) prohibits discrimination in hiring and promotion on the basis of physical disability. The BMC ADA Fume Hood is designed to provide a safe and comfortable work area for a wheelchair bound person. The extended height of the sash also makes the ADA Fume Hood a practical work station for a standing individual.

The ADA Fume Hood comes complete with a full framed combination horizontal/vertical sliding sash. The sash is glazed with 7/32" laminated safety glass and is counterweighted for one finger vertical operation. The four horizontal sliding panels glide on a dual track system for easy access into the Hood.

Double wall construction of the Hood superstructure allows for easy installation of service fixtures and service lines. The entrance of the Hood is framed with inward angled members to provide for smooth movement of air into the Hood. The interior lining is white "Resin-Chem" and has a removable access panel on each interior side.

*Fume Hood Superstructures are available in widths from 47" to 96", including PRIME-AIRE™'s unique 82" and 84" wide model as shown below. Service and electrical fixtures shown are optional and must be ordered separately.*

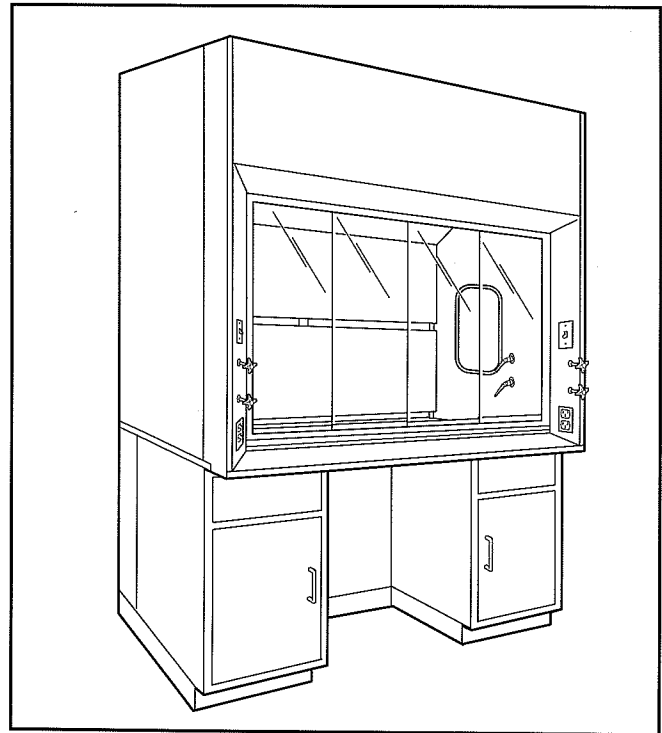

## Interior Lighting

A fluorescent light fixture, complete with tubes, illuminates the interior of the ADA Fume Hood. The light fixture is isolated from the Hood interior by a sealed safety glass panel. Relamping of the fixture is accomplished from the top front of the superstructure.

## Options

In addition to optional service and electrical fixtures for the ADA Fume Hood, **PRIME-AIRE™** also features an optional sash with a split viewing panel, secondary containment trough/airfoil, remote adjustable baffle, baffle screen, and air-flow monitor. Any or all of these options can be incorporated to meet specific needs or HOPEC requirements.

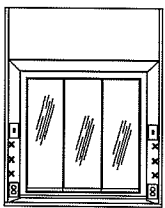

B-784 47"  
B-684 48"

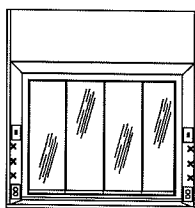

B-785 58"  
B-685 60"

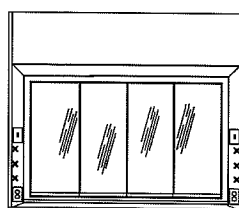

B-786 70"  
B-686 72"

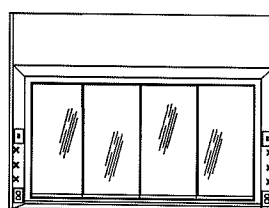

B-787 82"  
B-687 84"

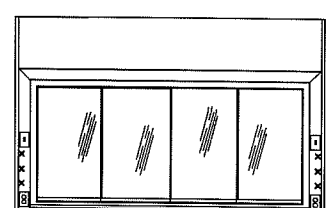

B-788 94"  
B-688 96"

The standard airfoil ADA Fume Hoods are each available as a complete assembly.

Detailed information on base cabinets, countertops and service fixtures is shown on pages 26, 28 and 29.

Each assembly includes two standard base cabinets (one on 47"/48" assembly), knee space area, two

LF35-7 filler panels, dished epoxy resin countertop, F-400 3" x 6" epoxy resin cupsink, three F-100 service fixtures, F-110 cold water fixtures, F-200 light switch, F-210 blower switch and two F-220 110V duplexes.

All service and electrical fixtures are furnished, but not installed.

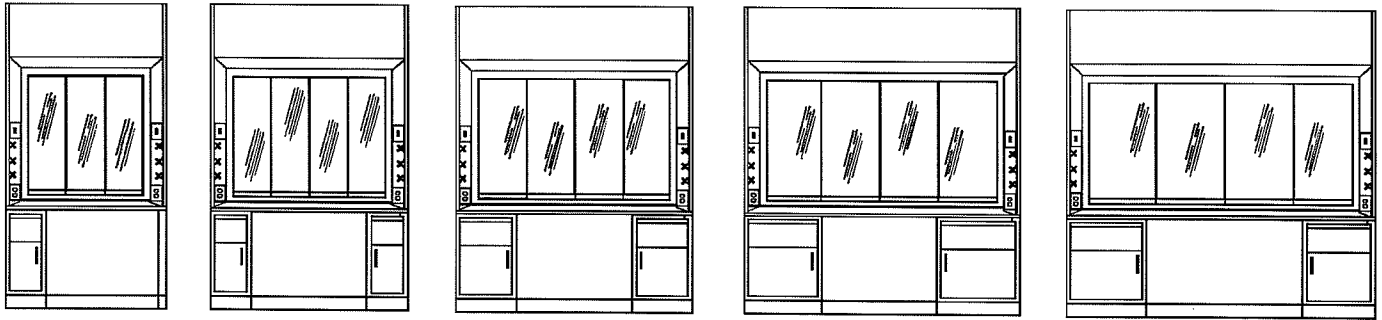

B-984 47"  
B-9840 48"

B-985 58"  
B-9850 60"

B-986 70"  
B-9860 72"

B-987 82"  
B-9870 84"

B-988 94"  
B-9880 96"

## Rough-in Details

HOOD SIZE	COLLAR SIZE	75 FPM		100 FPM		125 FPM		150 FPM	
		CFM	S.P.	CFM	S.P.	CFM	S.P.	CFM	S.P.
48"	6" x 12"	325	.05	433	.10	542	.15	650	.22
58"/60"	6" x 16"	441/425	.06/.05	588/567	.11/.09	735/708	.17/.15	882/850	.22/.21
70"/72"	6" x 20"	554/525	.06/.05	738/700	.11/.09	923/875	.17/.15	1107/1050	.22/.21
82"/84"	(2)6" x 12"	666/625	.06/.05	888/833	.11/.09	1110/1042	.17/.14	1332/1250	.22/.21
94"/96"	(2)6" x 12"	779/725	.07/.06	1038/967	.13/.11	1298/1208	.19/.18	1557/1450	.28/.25

The static pressures listed above are for the hoods only. An appropriate amount will have to be added to this figure to compensate for the pressure drop through the duct system. The total pressure drop through the hood and the duct system must be known to select the proper exhaust blower.

The CFM and static pressures listed above are measures with 50% of the sash area open.

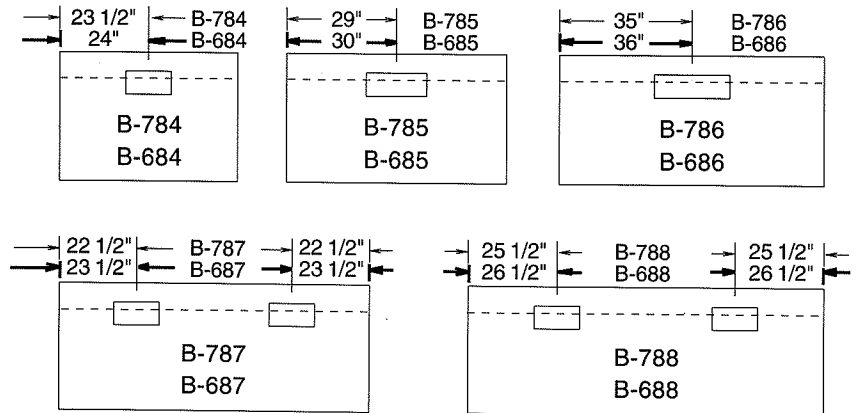
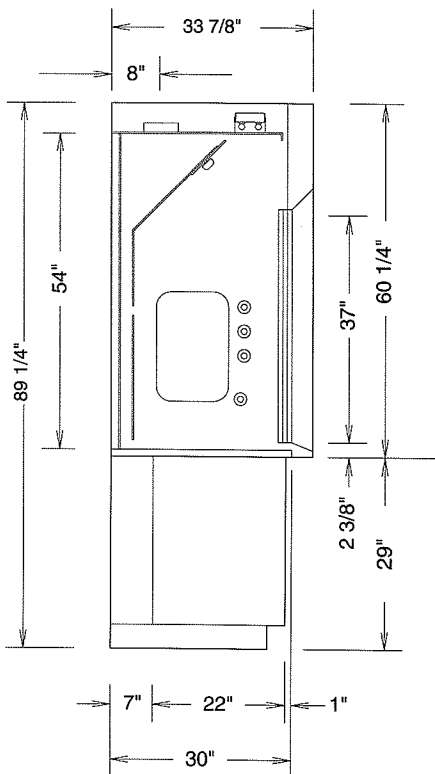

Duct collar locations are as shown above. The center line of each collar is 8" from the back of the hood. The area indicated by the dashed lines is designated for plumbing and electrical rough-ins. All rough-ins should be kept within 7" of the wall and 18" from the floor.

# Airfoil Radio Isotope Fume Hoods

**PRIME-AIRE™**

*Stainless steel lining and work surface with coved corners that facilitate thorough cleaning and a reinforced countertop to support lead bricks, are some of the features incorporated into the Radio Isotope Hood. These features will help to insure operator safety and convenience in procedures that involve the use and handling of radioactive materials.*

## Design

The Radio Isotope Hood comes equipped with a type 304 stainless steel sash frame with a full width flush pull and is glazed with 7/32" thick laminated safety glass. A counterweight provides for one finger operation of the sash at any position. A lower stainless steel airfoil acts as a sash stop to maintain a 1" space, below the closed sash, which allows air to continuously flow across the work surface.

The interior lining of the Radio Isotope Fume Hood is type 304 stainless steel. All seams are welded and ground smooth to eliminate the build-up of radioactive materials. The work surface, which is constructed of the same materials, is welded to the lining, making the liner and work surface integral and water tight. In addition, the work surface is reinforced to support 200 lbs. per square foot up to a total weight of 1,000 lbs. per Hood or base cabinet section.

Double wall construction of the Hood superstructure allows space for installation of service fixtures. Access for installation and maintenance is acquired through the removable stainless steel interior access panel or by removing the exterior side panel of the superstructure. A built-in bypass feature above the Hood sash works to maintain a relatively constant face velocity at any sash position.

*Fume Hood Superstructures are available in widths from 47" to 96", including PRIME-AIRE™'s unique 84" and 84" wide models as shown below. Service and electrical fixtures shown are optional and must be ordered separately.*

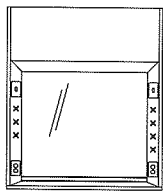

B-734 47"  
B-634 48"

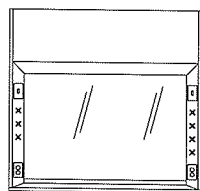

B-735 58"  
B-635 60"

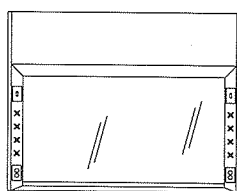

B-736 70"  
B-636 72"

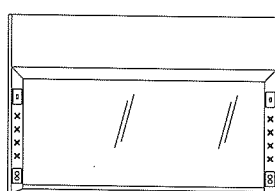

B-737 82"  
B-637 84"

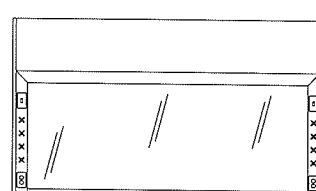

B-738 94"  
B-638 96"

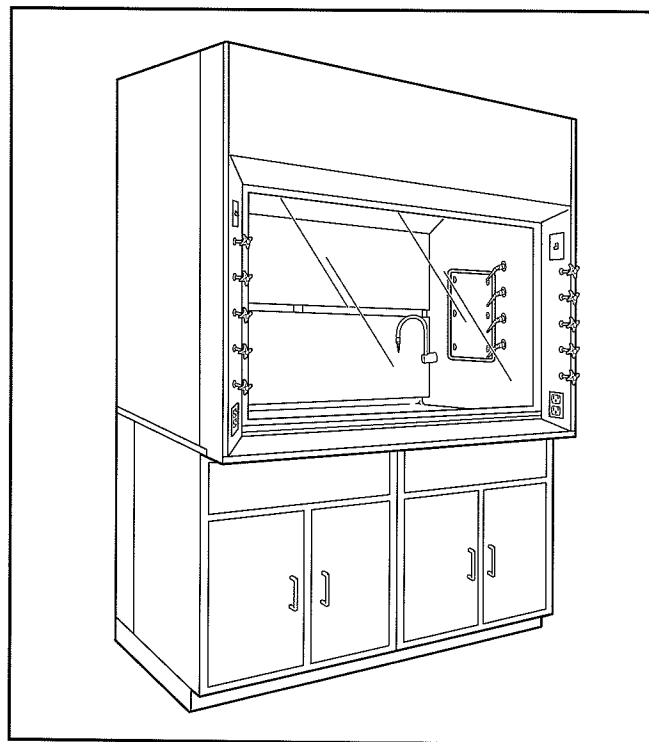

## Interior Lighting

The interior of the Radio Isotope Fume Hood is brightly lit by a maximum width dual fluorescent light fixture. The fixture is mounted behind a sealed safety glass panel to isolate the fixture from corrosive fumes and flammable vapors. Replacement of fluorescent tubes is accomplished from the exterior top front of the Fume Hood superstructure.

## Options

Optional service and electrical fixtures are available for installation in the Radio Isotope Fume Hood. Mounting holes are provided in the superstructure for on-site installation of the required service fixtures.

# Airfoil Radio Isotope Assemblies

**PRIME-AIRE™**

## Airfoil Radio Isotope Assemblies

The ten standard Fume Hood sizes are each available as a complete assembly.

Detailed information on base cabinets, countertop and service fixtures is shown on pages 26, 28 and 29.

The assembly for the 47"/48" and 58"/60" wide Hoods consists of a standard base cabinet, two LF35-7 filler

panels, 3" x 6" stainless steel cupsink, six F-100 service fixtures, F-110 cold water fixture, F-200 light switch, F-210 blower switch and two F-220 110V duplexes.

70"/72", 82"/84" and 94"/96" assemblies include all of the above along with a second base cabinet, cupsink and water fixture.

All service and electrical fixtures are furnished, but not installed.

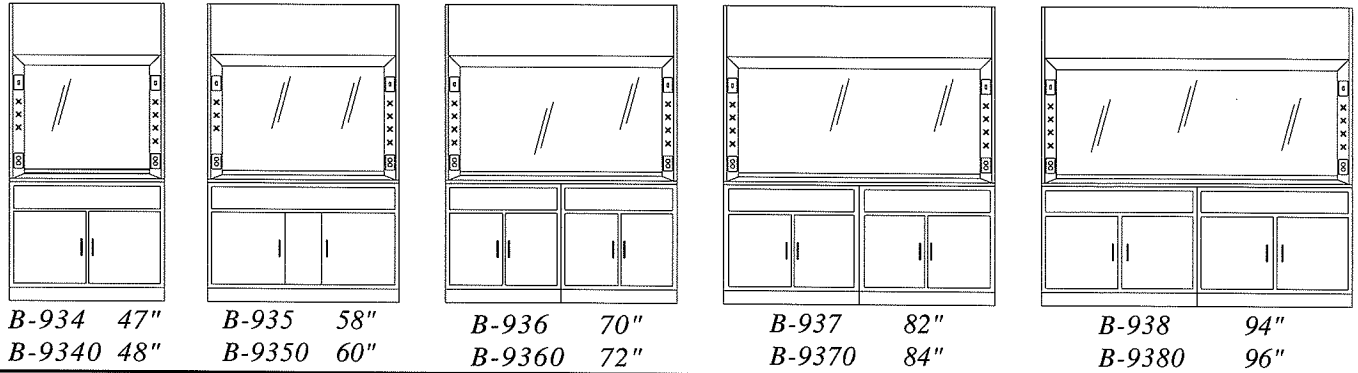

## Rough-in Details

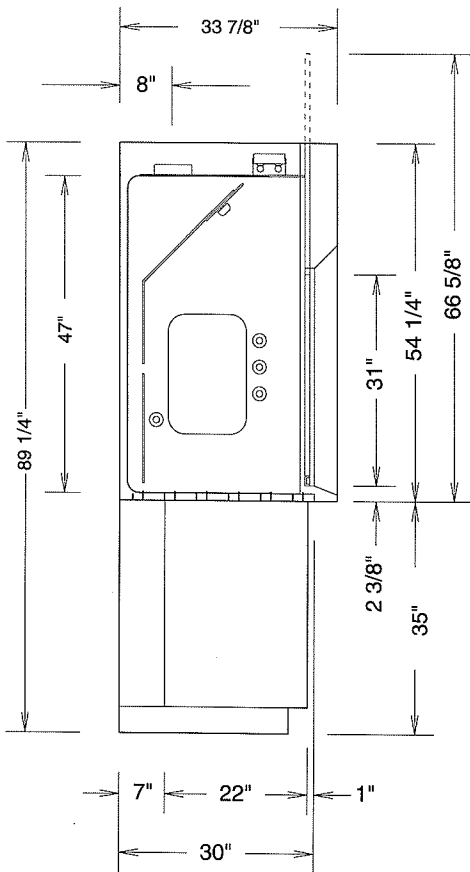

HOOD SIZE	COLLAR SIZE	75 FPM		100 FPM		125 FPM		150 FPM	
		CFM	S.P.	CFM	S.P.	CFM	S.P.	CFM	S.P.
47"/48"	6" x 12"	633/650	.21/.22	844/867	.37/.39	1055/1083	.58/.61	1266/1300	.83/.87
58"/60"	6" x 16"	817/850	.20/.21	1089/1133	.36/.38	1361/1417	.56/.59	1634/1700	.81/.85
70"/72"	6" x 20"	1016/1050	.21/.21	1355/1400	.38/.37	1694/1750	.56/.58	2033/2100	.81/.84
82"/84"	(2)6" x 12"	1212/1250	.19/.21	1616/1667	.35/.37	2020/2083	.60/.58	2492/2500	.85/.83
94"/96"	(2)6" x 12"	1417/1450	.23/.25	1889/1933	.42/.45	2361/2417	.65/.71	2834/2900	.93/1.02

The static pressures listed above are for the hoods only. An appropriate amount will have to be added to this figure to compensate for the pressure drop through the duct system. The total pressure drop through the hood and the duct system must be known to select the proper exhaust blower.

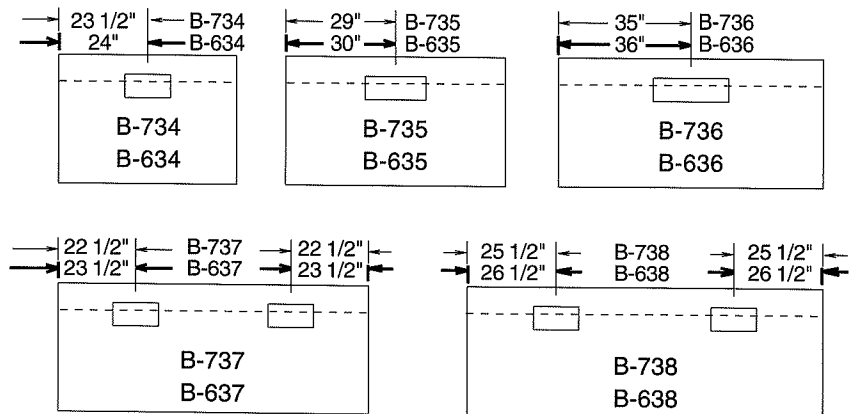

Duct collar locations are as shown above. The center line of each collar is 8" from the back of the hood. The area indicated by the dashed lines is designated for plumbing and electrical rough-ins. All rough-ins should be kept within 7" of the wall and 18" from the floor.



# Airfoil Perchloric Acid Fume Hoods

**PRIME-AIRE™**

This Fume Hood is specifically designed for the use of perchloric acid. A coved stainless steel liner with integral work surface, an internal water wash down system and water collection trough provide for detailed cleaning of the Hood interior. In addition, the interior baffles are also removable for cleaning to prevent the dangerous build-up of perchlorates.

## Design

The Perchloric Acid Fume Hood has an internal bypass located above the sash. The bypass operates automatically, opening when the sash is closed and closing as the sash is raised. The bypass provides for a relatively constant face velocity at any sash position.

The sash frame and lower airfoil are constructed of type 316 stainless steel. The sash is glazed with 7/32" thick laminated safety glass and has full width pull and counterweight for easy up/down operation. In the closed position, the lower airfoil acts as a sash stop providing a 1" space for air to continuously sweep the work surfaces.

The interior liner, work surface and baffles are also constructed of type 316 stainless steel. A wash down spray bar is located behind the upper baffle for continuous cleaning behind the baffles. A full width trough is located below the lower baffle to collect the wash down water from both the Hood and ductwork.

Double wall construction of the superstructure allows for installation of service fixtures and routing of interior plumbing and electrical lines. Access for installation and maintenance of service fixtures is obtained by removing the exterior side panel.

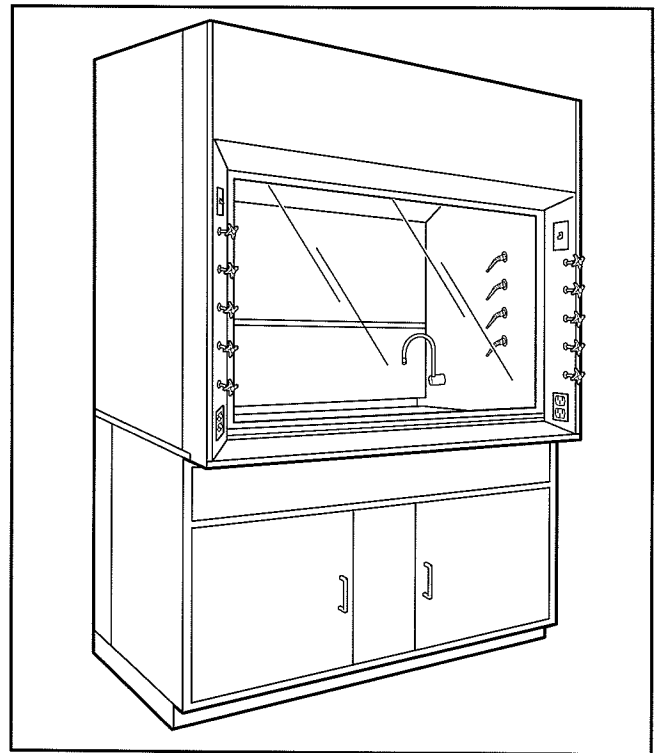

## Interior Lighting

A two tube fluorescent light fixture illuminates the interior of the Perchloric Acid Fume Hood. The fixture is mounted behind a sealed safety glass panel to isolate the fixture from corrosive fumes and flammable vapors. Replacement of fluorescent tubes is accomplished from the exterior top front of the Fume Hood superstructure.

## Options

A variety of optional service fixtures are available from **PRIME-AIRE™**. The location of the fixtures must be specified for accurate cutting of the mounting holes located in the Fume Hood lining.

Fume Hood Superstructures are available in widths from 47" to 96", including **PRIME-AIRE's** unique 82" and 84" wide model as shown below. Service and electrical fixtures shown are optional and must be ordered separately.

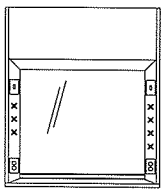

B-744 47"  
B-644 48"

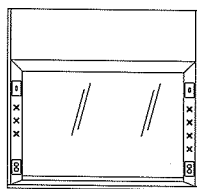

B-745 58"  
B-645 60"

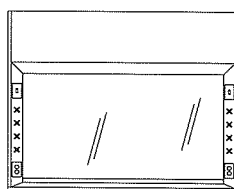

B-746 70"  
B-646 72"

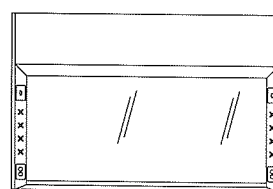

B-747 82"  
B-647 84"

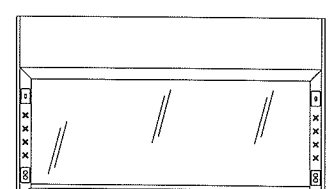

B-748 94"  
B-648 96"

## Airfoil Perchloric Acid Assemblies

The ten standard Fume Hood sizes are each available as a complete assembly.

Detailed information on base cabinets, countertops and service fixtures is shown on pages 26, 28 and 29.

The assembly for the 47"/48" and 58"/60" wide Hoods consists of a standard base cabinet, two LF35-7 filler

panels, 3" x 6" stainless steel cupsink, six F-100 service fixtures, F-110 cold water fixture, F-200 light switch, F-210 blower switch and two F-220 110V duplexes.

70"/72", 82"/84" and 94"/96" assemblies include all of the above along with a second base cabinet, cupsink and water fixture.

All service and electrical fixtures are furnished, but not installed.

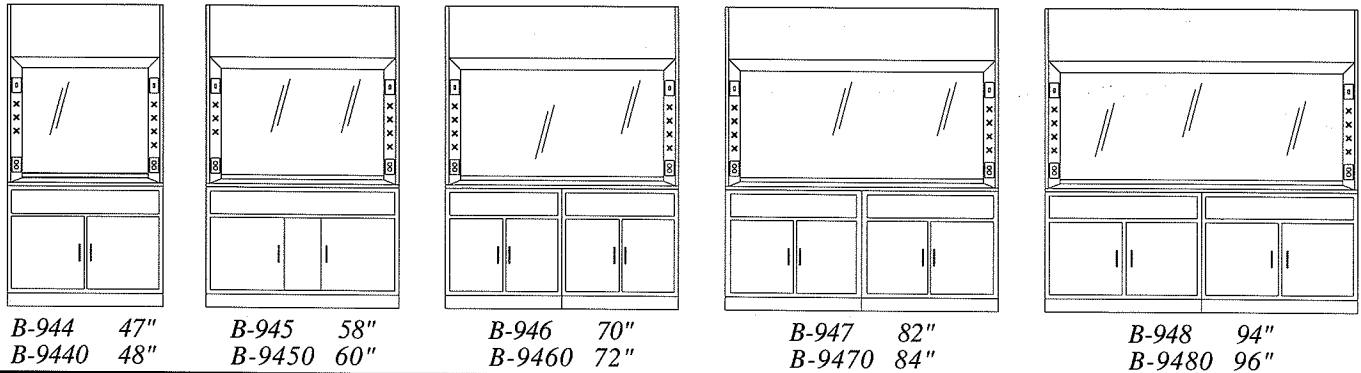

## Rough-in Details

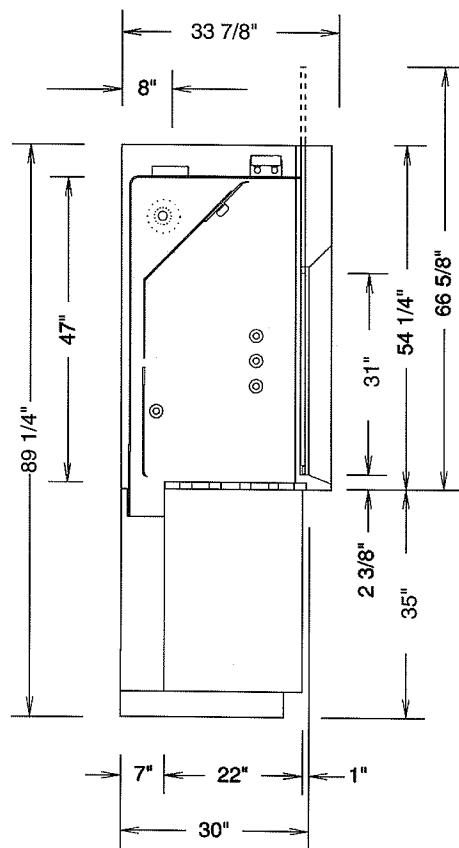

HOOD SIZE	COLLAR SIZE	75 FPM		100 FPM		125 FPM		150 FPM	
		CFM	S.P.	CFM	S.P.	CFM	S.P.	CFM	S.P.
47"/48"	6" x 12"	633/650	.21/.22	844/867	.37/.39	1055/1083	.58/.61	1266/1300	.83/.87
58"/60"	6" x 16"	817/850	.20/.21	1089/1133	.36/.38	1361/1417	.56/.59	1634/1700	.81/.85
70"/72"	6" x 20"	1016/1050	.21/.21	1355/1400	.38/.37	1694/1750	.56/.58	2033/2100	.81/.84
82"/84"	(2)6" x 12"	1212/1250	.19/.21	1616/1667	.35/.37	2020/2083	.60/.58	2492/2500	.85/.83
94"/96"	(2)6" x 12"	1417/1450	.23/.25	1889/1933	.42/.45	2361/2417	.65/.71	2834/2900	.93/1.02

The static pressures listed above are for the hoods only. An appropriate amount will have to be added to this figure to compensate for the pressure drop through the duct system. The total pressure drop through the hood and the duct system must be known to select the proper exhaust blower.

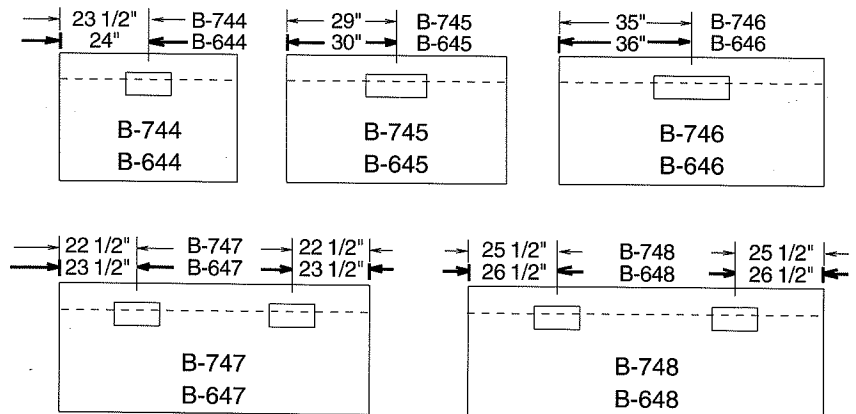

Duct collar locations are as shown above. The center line of each collar is 8" from the back of the hood. The area indicated by the dashed lines is designated for plumbing and electrical rough-ins. All rough-ins should be kept within 7" of the wall and 18" from the floor.

# Airfoil Low Bench & Walk-In Fume Hoods

**PRIME-AIRE™**

Large apparatus or complex set-ups may require the use of a Fume Hood specifically designed to meet these requirements. The **PRIME-AIRE™** Low Bench Fume Hood is supported by an 18" high table and has an interior height of 63 3/4". The Walk-In Fume Hood has two vertical rising sashes that allow you to roll in large equipment or portable work stations.

## Design

The Low Bench Fume Hood has a four panel horizontal sliding sash. Each panel is a 7/32" thick laminated safety glass and is trimmed on the edges with stainless steel "U" channel.

The Walk-In Fume Hood is equipped with two independently operating, full view, vertical rising sash. Each sash is glazed with 7/32" laminated safety glass and is counterweighted for one finger operation at any position.

Both Low Bench and Walk-In Hoods are framed with inward angled members to minimize turbulence and provide smooth movement of air into the Hood. The lower airfoil on the Low Bench Hood maintains a 1" space, below the horizontal sliding sash panels, which allows air to flow continuously across the work surface of the Hood.

Low Bench and Walk-In Hoods have a double wall construction that allows for easy installation of service fixtures and routing of interior plumbing and electrical lines. The Hood interior is white "Resin-Chem" and has removable interior access panels on both sides.

Fume Hood Superstructures are available in widths of 70"/72" and 94"/96". Special sizes are also available; contact your **PRIME-AIRE™** representative for details. Service and electrical fixtures shown are optional and must be ordered separately.

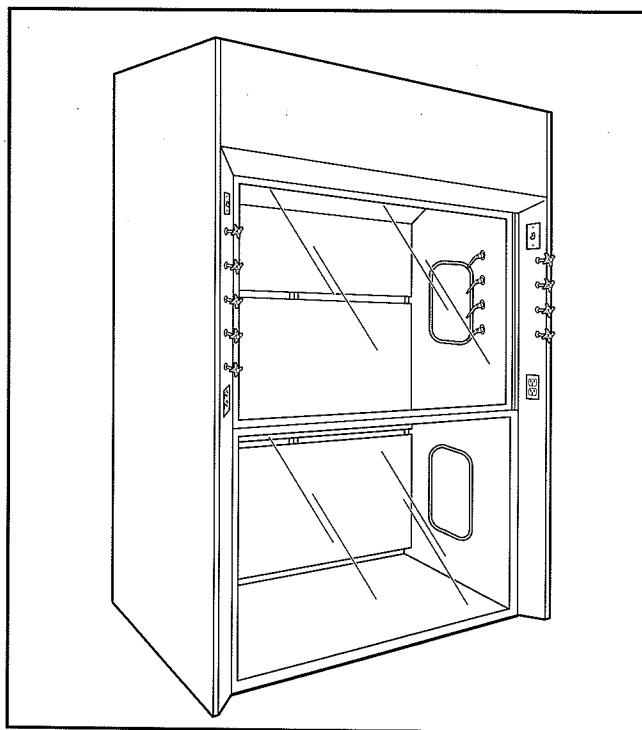

## Interior Lighting

A maximum width, two tube light fixture, complete with tubes, is provided with the Low Bench and Walk-In Hoods. The light fixture is mounted above a sealed safety glass panel isolating it from corrosive fumes and hazardous vapors. The tube lights are easily replaced through the top front of the Fume Hood superstructure.

## Options

A variety of service fixtures are available for installation in the Low Bench and Walk-In Fume Hoods. Mounting holes for fixtures and electrical receptacles are provided in the superstructures for final on-site installation of optional equipment.

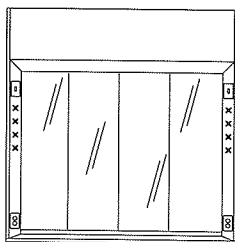

B-756 70"  
B-656 72"

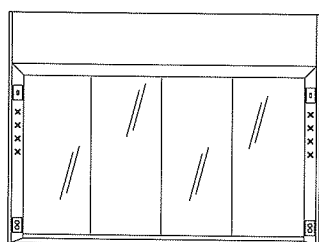

B-758 94"  
B-658 96"

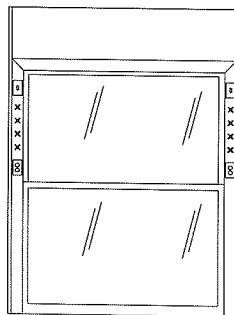

B-766 70"  
B-666 72"

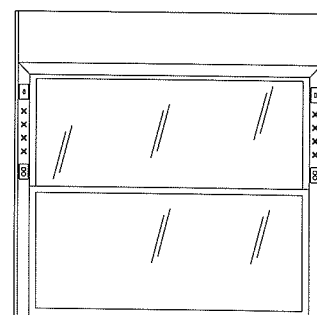

B-768 94"  
B-668 96"

# Airfoil Low Bench & Walk-In Assemblies

**PRIME-AIRE™**

## Low Bench & Walk-In Assemblies

Standard Fume Hood sizes are each available as a complete assembly.

Detailed information on countertops and service fixtures is shown on pages 28 and 29.

The assembly for the Low Bench Hoods consist of an 18" high table, a dished epoxy resin countertop, two F-400 3"x6" epoxy resin cupsinks, six F-100 service fixtures, two F-110

cold water fixtures, F-200 light switch, F-210 blower switch and two F-220 duplexes.

Walk-In assemblies consist of two F-401 side mount cupsinks, six F-100 service fixtures, two F-110 cold water fixtures, F-200 light switch, F-210 blower switch and two F-220 110V duplexes.

All service and electrical fixtures are furnished, but not installed.

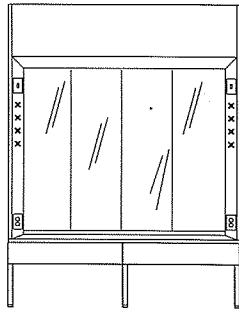

B-956 70"  
B-9560 72"

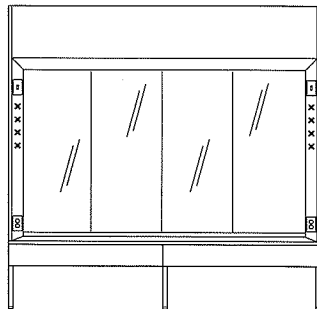

B-958 94"  
B-9580 96"

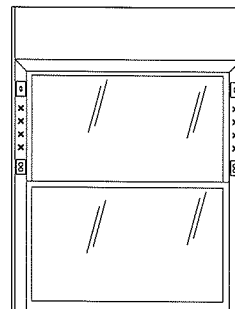

B-966 70"  
B-9660 72"

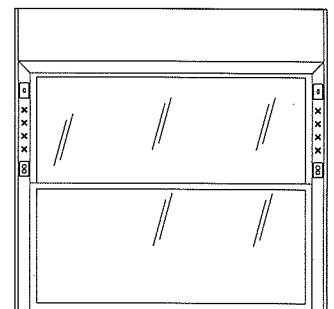

B-968 94"  
B-9680 96"

## Rough-in Details

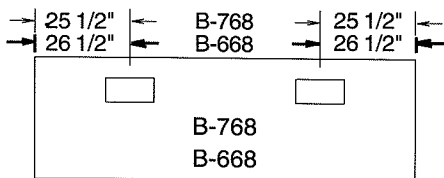
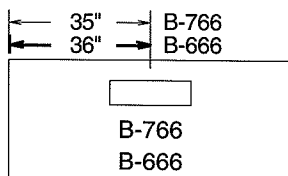
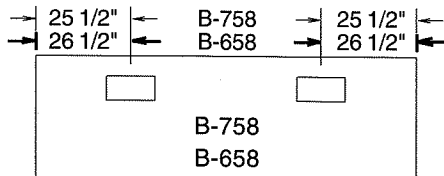
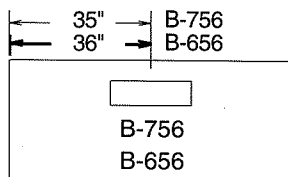

HOOD SIZE	COLLAR SIZE	75 FPM		100 FPM		125 FPM		150 FPM	
		CFM	S.P.	CFM	S.P.	CFM	S.P.	CFM	S.P.
70"/72" LB	6" x 20"	808/831	.13/.13	1078/1107	.22/.23	1347/1384	.33/.36	1616/1661	.48/.52
94"/96" LB	(2) 6" x 12"	1132/1147	.14/.16	1509/1529	.25/.28	1886/1912	.39/.44	2264/2294	.57/.64
70"/72" WI	6" x 20"	1056/1181	.19/.26	1408/1575	.32/.47	1760/1969	.50/.74	2112/2363	.75/1.06
94"/96" WI	(2) 6" x 12"	1473/1631	.22/.32	1964/2175	.40/.57	2455/2719	.62/.89	2946/3263	.89/1.29

The static pressures listed above are for the hoods only. An appropriate amount will have to be added to this figure to compensate for the pressure drop through the duct system. The total pressure drop through the hood and the duct system must be known to select the proper exhaust blower.

The CFM and static pressures listed above are measured with 50% of the sash area open.

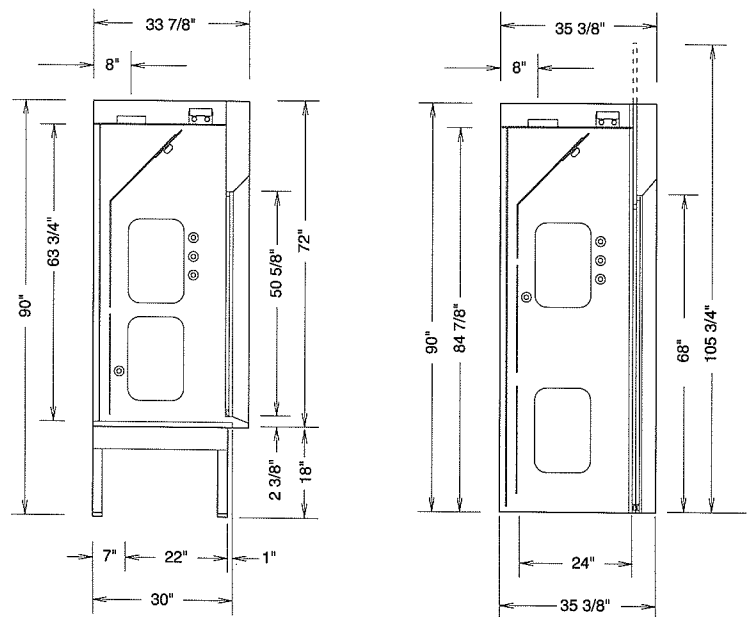

Duct collar locations are as shown above. The center line of each collar is 8" from the back of the hood.

# Thin Wall Fume Hoods

**PRIME-AIRE™**

The **PRIME-AIRE™** Thin Wall Fume Hood provides an excellent low cost means of exhausting high heat loads and non-hazardous fumes.

The Thin Wall design allows for maximum interior work area and is well suited for installation on any counter of 30" depth.

## Design

The exterior of the Thin Wall Fume Hood is 18 gage steel with an epoxy powder coat finish, front posts are stainless steel with a #4 finish. These components are attached to a heavy gage internal framework. This framework is welded and bolted together to provide a ridged durable structure for the Thin Wall Hood.

The interior of the Hood is lined with Minerit, a chemical resistant gray composition stone material. The liner is attached to the internal framework with the use of non-metallic fasteners. A lintel, of the same material, restricts the air intake of the Hood to the sash opening. This restriction allows you to vary the face velocity of the Thin Wall Fume Hood by changing the sash position. An interior baffle system, also constructed of minerit, maintains a uniform face velocity across the entire opening of the sash. The upper portion of the baffle is adjustable to compensate for high heat loads or light fumes.

The full view sash of the Thin Wall Hood is framed with a chemical resistant black PVC. It is glazed with 7/32" thick laminated safety glass and has a single counterweight for easy up/down operations.

Fume Hood Superstructures are available in widths from 47" to 96", including **PRIME-AIRE™**'s unique 82" and 84" wide model as shown below. Service and electrical fixtures shown are optional and must be ordered separately.

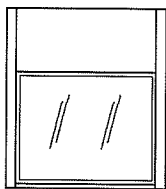

B-824 47"  
B-834 48"

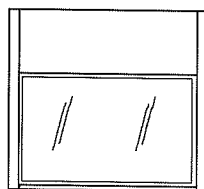

B-825 58"  
B-835 60"

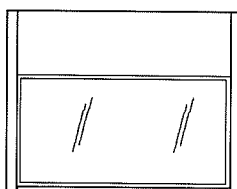

B-826 70"  
B-836 72"

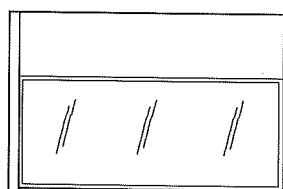

B-827 82"  
B-837 84"

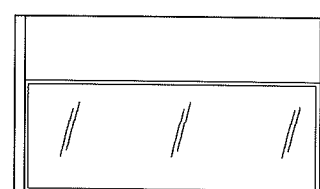

B-828 94"  
B-838 96"

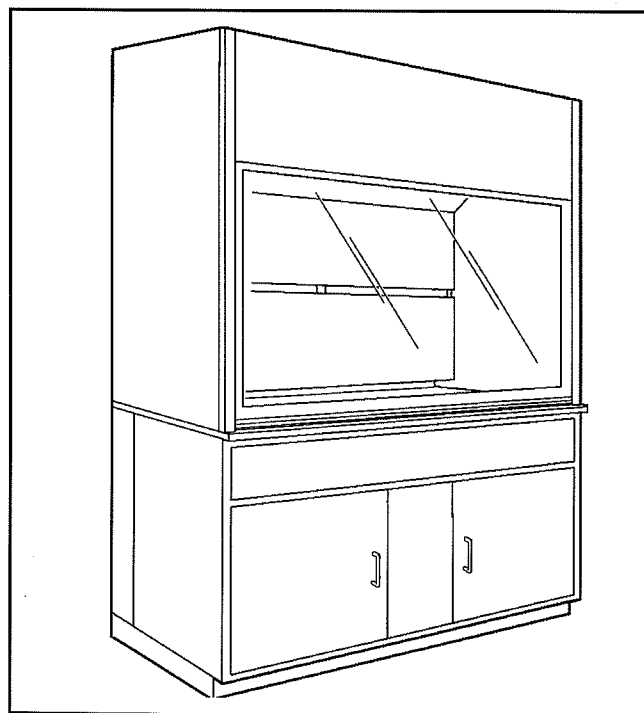

## Interior Lighting

The interior of the Thin Wall Fume Hood is brightly lit by a vapor proof incandescent light fixture, bulb included. A single light fixture is provided in 47"/48", 58"/60" and 70"/72" models and two fixtures are provided in the other models. Replacement of the incandescent bulbs is accomplished from the interior of the Hood.

## Options

Switches, outlets, and remote valves must be located on the front panel of the Fume Hood base cabinet. Refer to pages 28 and 29 for details.

## Thin Wall Fume Hood Assemblies

The ten standard Fume Hood sizes are each available as a complete assembly.

Detailed information on base cabinets and service fixtures is shown on pages 26, 28 and 29.

Assemblies for 47"/48" and 58"/60" wide Fume Hoods

consist of a standard base cabinet, two LF35-7 filler panels, a 1" thick black epoxy resin countertop, F-200 light switch, F-210 blower switch and two F-220 110V duplexes.

70"/72", 82"/84" and 94"/96" assemblies include all of the above along with a second base cabinet. Electrical fixtures are furnished but not installed.

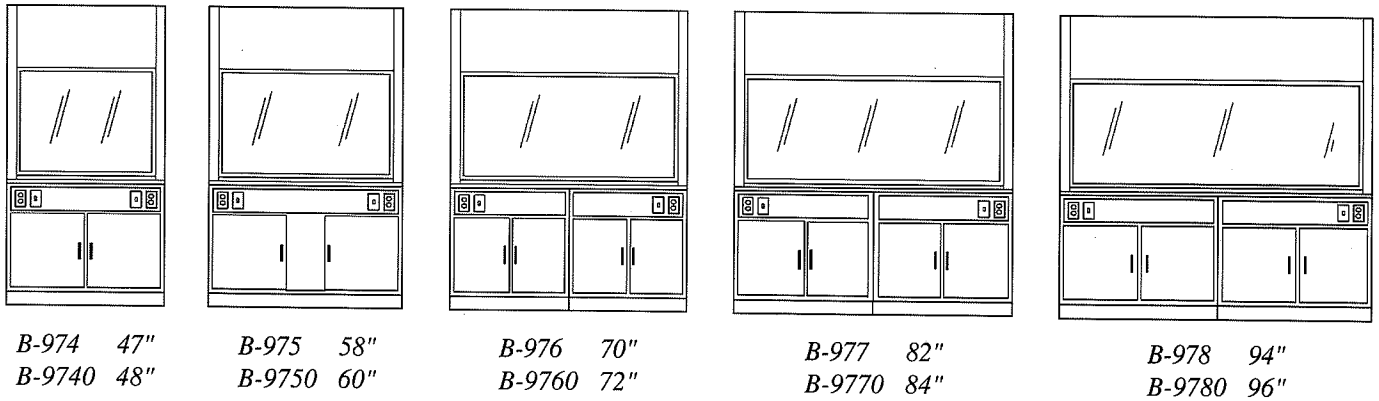

## Rough-in Details

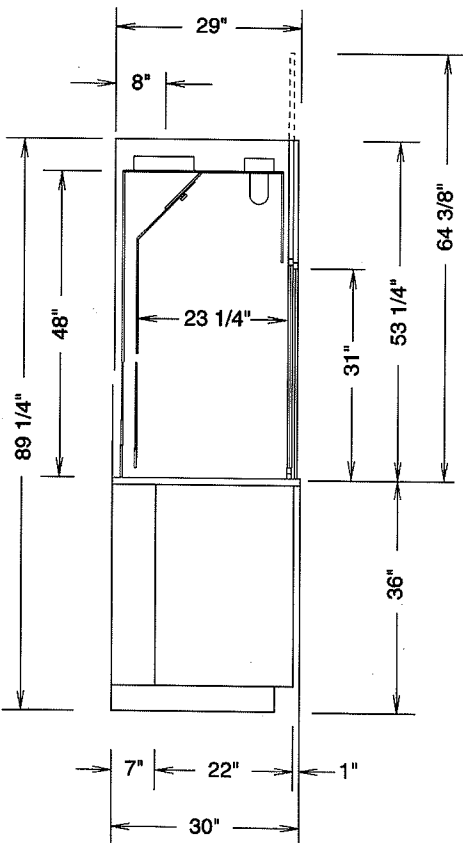

HOOD SIZE	COLLAR SIZE	75 FPM		100 FPM		125 FPM		150 FPM	
		CFM	S.P.	CFM	S.P.	CFM	S.P.	CFM	S.P.
47"/48"	9" DIA.	694/710	.28/.29	926/947	.50/.51	1157/1184	.78/.80	1389/1421	1.12/1.16
58"/60"	10" DIA.	872/904	.29/.30	1163/1206	.51/.54	1453/1507	.80/.84	1744/1808	1.15/1.21
70"/72"	10" DIA.	1066/1098	.39/.41	1421/1464	.69/.72	1776/1830	1.08/1.13	2131/2196	1.55/1.63
82"/84"	(2) 9" DIA.	1259/1292	.24/.25	1679/1722	.43/.45	2099/2153	.68/.70	2519/2583	.97/1.01
94"/96"	(2) 9" DIA.	1453/1485	.30/.31	1938/1981	.53/.55	2422/2476	.83/.86	2906/2971	1.20/1.24

The static pressures listed above are for pressure drop through the hoods only. An appropriate amount will have to be added to this figure to compensate for the pressure drop through the duct system. The total pressure drop through the hood and the duct system must be known to select the proper exhaust blower.

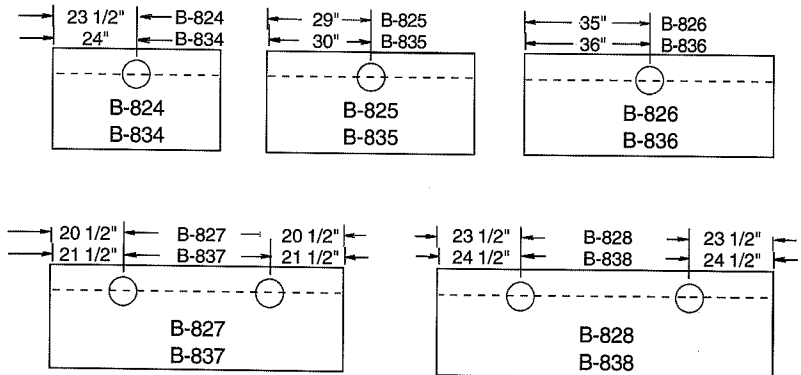

Duct collar locations are as shown above. The center line of each collar is 8" from the back of the hood. The area indicated by the dashed lines is designated for plumbing and electrical rough-ins. All rough-ins should be kept within 7" of the wall and 18" from the floor.

# Demonstration Fume Hoods

**PRIME-AIRE™**

The PRIME-AIRE™ Demonstration Fume Hoods feature dual access sashes and offer a clear, unobstructed view of the Hood interior.

## Design

Two independently operating sashes provide viewing and access from either side of the Demonstration Fume Hood. A fixed end window is also provided to increase the interior viewing.

Sashes are glazed with laminated safety glass and have a full width PVC pull for maximum chemical resistance. The Hood interior is lined with chemical resistant "Resin-Chem" and is illuminated with a vapor proof incandescent light fixture.

## Options

Two 3-way switches, a blower switch and two duplex outlets are available for installation on the Demonstration Hood. These items are optional and must be ordered separately.

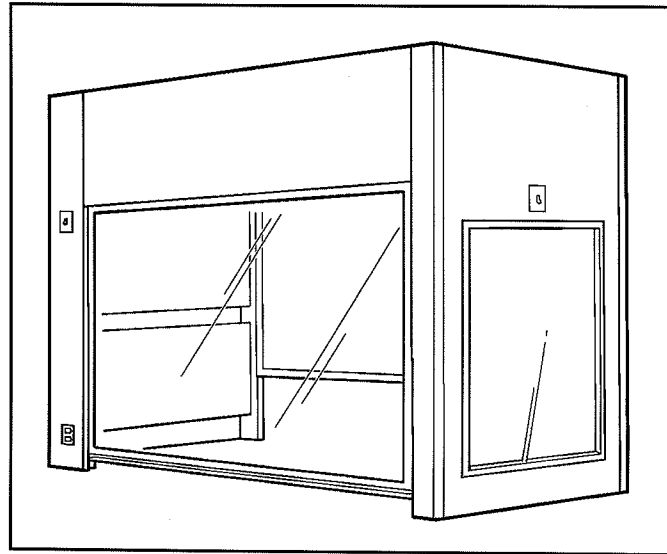

## Rough-in Details

MODEL NUMBER	SIZE	COLLAR SIZE	75 FPM		100 FPM		125 FPM		150 FPM	
			CFM	S.P.	CFM	S.P.	CFM	S.P.	CFM	S.P.
B-814	48"	6" x 16"	569	.20	758	.36	948	.56	1137	.80
B-815	59"	6" x 16"	729	.33	972	.59	1215	.92	1458	1.32
B-816	60"	6" x 16"	744	.34	992	.61	1240	.96	1488	1.38

The static pressures listed above are for pressure drop through the hoods only. An appropriate amount will have to be added to this figure to compensate for the pressure drop through the duct system. The total pressure drop through the hood and the duct system must be known to select the proper exhaust blower.

The CFM and static pressures listed above are measured with one sash open.

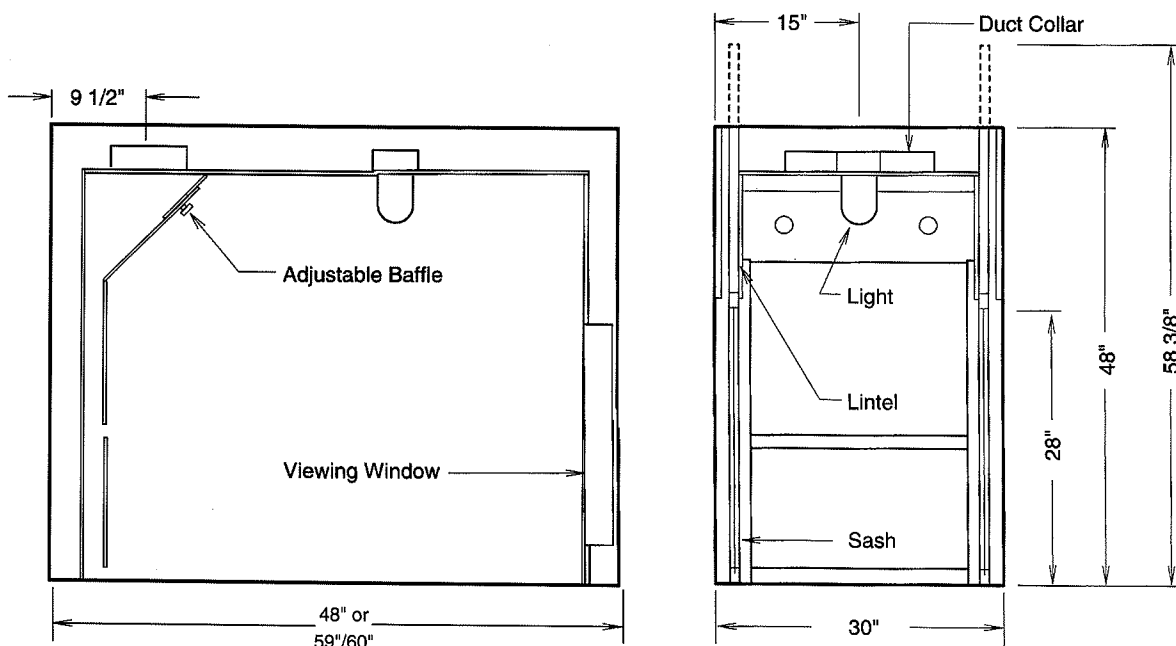

# Portable Fume Hood

**PRIME-AIRE™**

The **PRIME-AIRE™** Portable Fume Hood features safety and convenience. Mobile design allows the Portable Fume Hood to be wheeled into a working position and moved back to a storage location when the task is complete. Clear view side and back panels make the Portable Fume Hood ideally suited for demonstrations. It also allows instructor observation when being used as a student work station.

## Design

The framework of the Portable Fume Hood is fully welded, painted square tubing. The upper metal housing contains a single tube fluorescent light (bulb included), exhaust fan, light and fan switches, duplex outlet and a double sided gas hose connector. The interior work surface is black epoxy resin and is enclosed with 1/4" plexiglass viewing panels. The front viewing panel is hinged for easy access. Additional features include locking swivel casters, six foot long power cord and six feet of 2" diameter flexible exhaust duct.

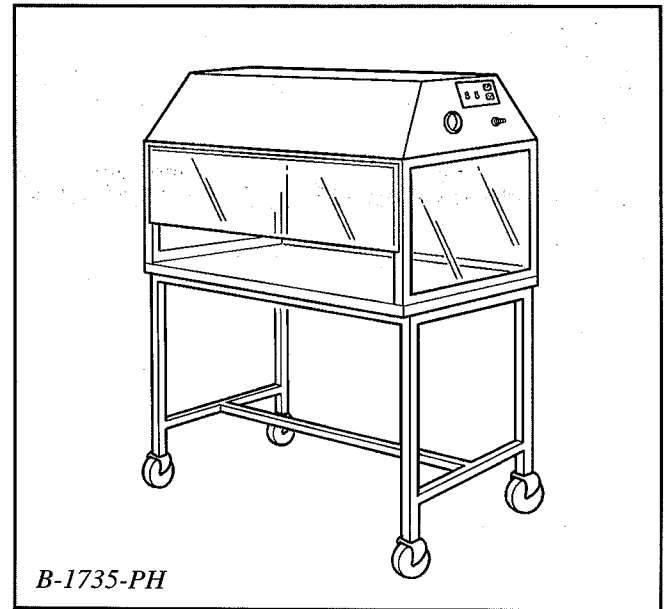

B-1735-PH

## Rough-in Details

The amount of air being exhausted through the hood will vary depending on the length and shape of the ductwork. The chart below shows the exhaust volume (CFM) at various static pressures. For installations requiring long runs of ductwork, a supplemental exhaust system may be required.

Exhaust fan is 115 V, 60 CY, 2870 RPM

MODEL NUMBER	COLLAR SIZE	CFM AT STATIC PRESSURE SHOWN											
		S.P.	CFM	S.P.	CFM	S.P.	CFM	S.P.	CFM	S.P.	CFM	S.P.	CFM
B-1735-PH	2" DIA.	FREE AIR	100	.1	98	.2	95	.3	90	.4	85	.5	80

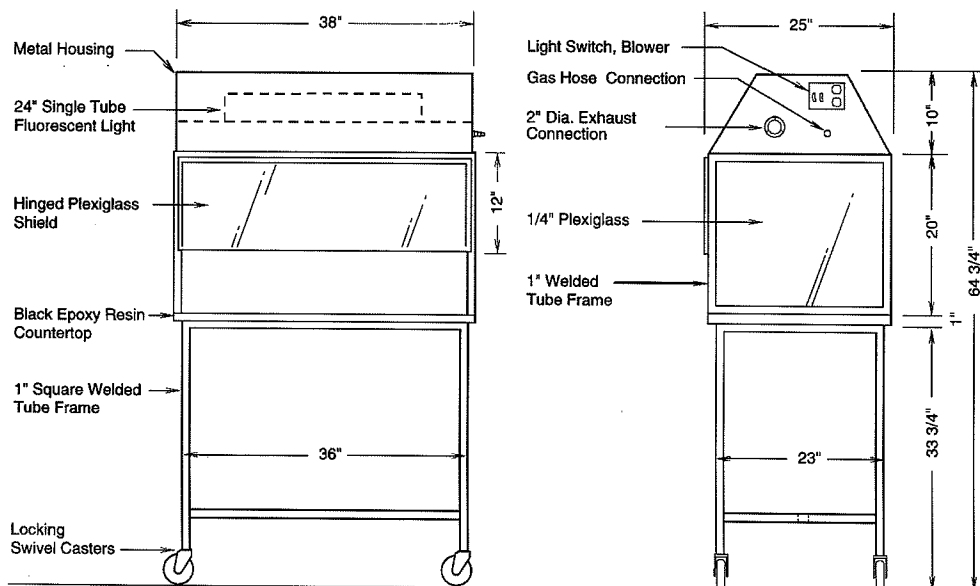



The **PRIME-AIRE™** Spray Booth offers an economical way to exhaust odors and non-toxic fumes in Laboratory, Class Room and Shop environments.

## Design

The **PRIME-AIRE™** Spray Booth is constructed of 18 gage steel that is formed and welded into a rigid superstructure. Each unit is finished with a chemical resistant powder coat paint finish and has a replaceable, pleated air filter.

The Spray Booth is designed to have a non-explosion proof exhaust blower (specified on the next page) mounted directly on top of the unit. A rectangular duct transition is included to connect the exhaust blower to the Spray Booth. For flammable fumes or vapors, an optional explosion proof exhaust blower must be specified. The explosion proof exhaust blower is designed to be mounted on the roof or other suitable location, but not on top of the Spray Booth.

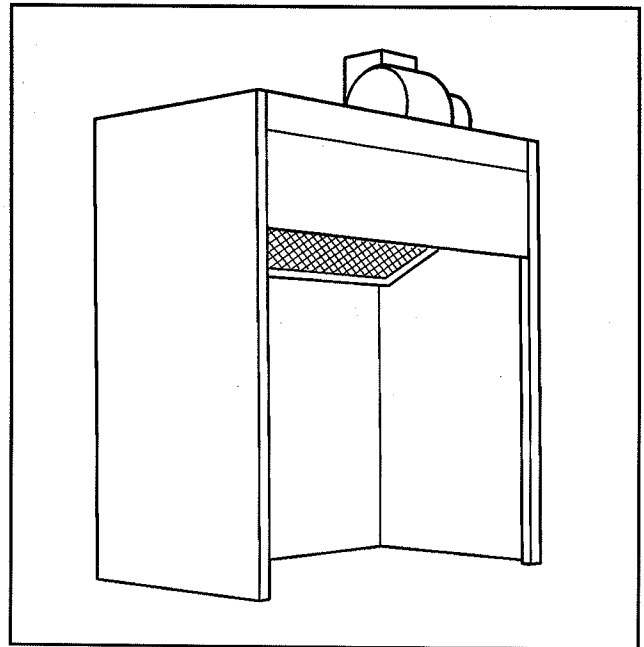

## Interior Lighting

The interior of the Spray Booth is illuminated by a vapor proof incandescent light fixture (bulb included). Light bulb replacement is accomplished from the interior of the booth.

When exhausting flammable fumes or vapors, an optional explosion proof light fixture must be specified.

## Options

Optional service and electrical fixtures are available for use with the **PRIME-AIRE™** Spray Booth. Contact your **PRIME-AIRE™** representative to assist you in specifying these items.

*Spray Booth Superstructures are available in widths from 24" to 48" as shown below.*

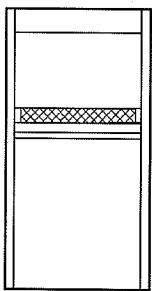

B-810 24"

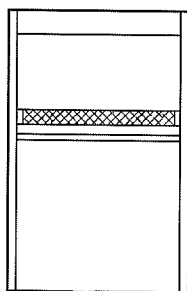

B-811 30"

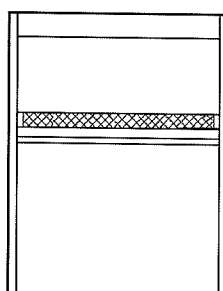

B-812 36"

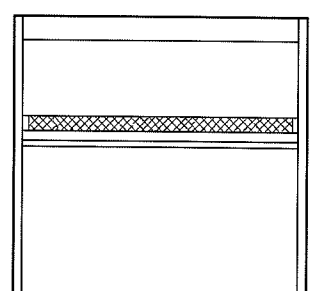

B-813 48"

## Exhaust Blowers

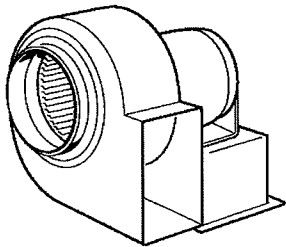

HOOD SIZE	MODEL NUMBER	OUTLET SIZE	HP	CFM AT STATIC PRESSURE SHOWN					
				.125	.25	.375	.5	.625	.75
24"	7C037	4 1/4" x 7 3/8"	1/4	560	515	470	420	360	300
30"	7C038	5 3/8" x 8 1/4"	1/3	920	870	820	765	710	655
36"	7C039	6 1/2" x 10 3/4"	1/3	968	930	890	850	810	773
48"	7C647	6 1/2" x 10 3/4"	1/3	1160	1125	1090	1035	963	855

Exhaust Blowers feature a dynamically balanced forward curve wheel with cast iron hubs. Housing and motorbase are 16 gage steel with a gray baked-on epoxy finish.

Motors are 115V/60HZ with H.P. as shown above.

Contact your **PRIME-AIRE™** representative to assist you in specifying an explosion proof exhaust blower.

## Replacement Filters

HOOD SIZE	FILTER NUMBER	QUANTITY	SIZE
24"	6556	1	16"X20"
30"	6557	1	22"X20"
36"	6558	2	14"X20"
48"	6559	2	20"X20"

Spray Booth replacement filters are a 1" thick cotton polyester blended filter, laminated to a galvanized steel expanded metal support grid. Order by part number from the chart to the left. (Note: 36" and 48" Spray Booths require two filters.)

## Rough-in Details

HOOD SIZE	DIMENSIONS				
	"A"	"C"	"B"	"D"	"E"
24"	7"	4 3/4"	10 7/16"	10 3/8"	6"
30"	7"	7 3/4"	8"	14"	6"
36"	7"	10 3/4"	10 7/8"	17 5/8"	6 7/8"
48"	7"	19 3/4"	10 7/8"	26 5/8"	6 7/8"

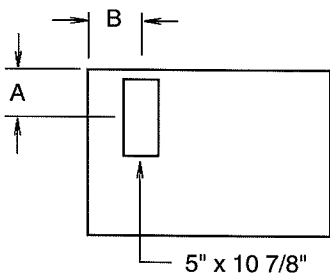

Plan View of Spray Booth Top Without Blower

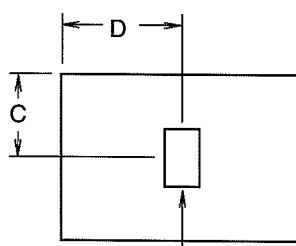

Plan View of Spray Booth Top With Blower

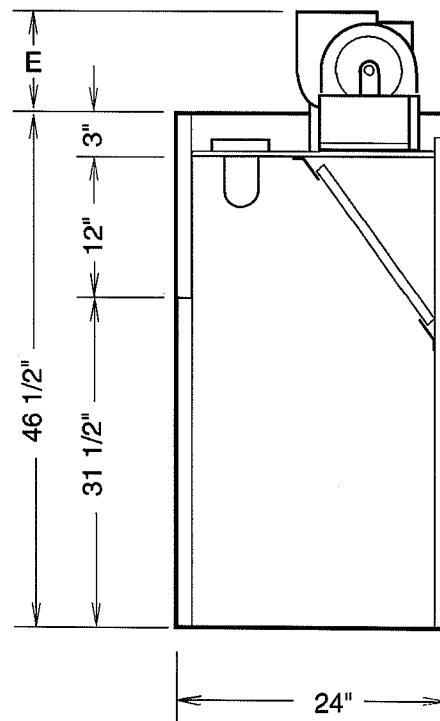

## Canopy Hoods

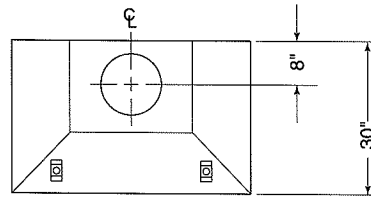
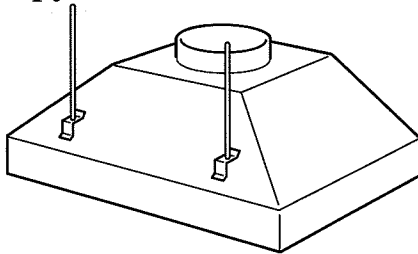

\* Threaded Rods NOT included

MODEL NUMBER	SIZE	COLLAR SIZE	50 FPM	
			CFM	S.P.
B-773/B-7730	35"/36"	10"/12"	N/A/963	N/A/.16
B-774/B-7740	47"/48"	12"/12"	N/A/1138	N/A/.17
B-776/B-7760	70"/72"	12"/12"	N/A/1502	N/A/.36

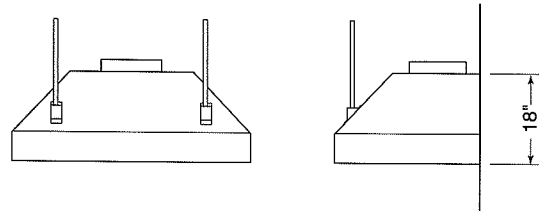

Canopy Hoods are specifically designed for exhausting non-hazardous materials such as heat, steam and odors.

Canopy Hoods are constructed of epoxy coated steel in any of our standard colors. Six sizes are available for wall or corner mounting. Due to the many variations in wall and ceiling construction, mounting hardware is not included. Special size and configuration Canopy Hoods are available upon request.

The CFM listed above is based on 50 FPM with the Canopy Hood mounted 42" above the work surface and the front and one side open. The static pressures shown are for the Hood only. An appropriate amount will have to be added to this figure to compensate for the pressure drop through the duct system. The total pressure drop through the Hood and the duct system must be known to select the proper exhaust blower.

## Fume Hood Base Cabinets

**PRIME-AIRE™** Fume Hood base cabinets feature heavy duty flush front construction. Cabinet bottoms are panned up for easy cleaning, cabinet backs are removable for access to service lines. Doors are double pan, sound deadened construction supported with five knuckle stainless steel hinges. Shelves are full depth and adjustable on 1" increments.

Cabinets are coated with a baked on epoxy finish in your choice of standard colors. All cabinets are 18" deep.

Acid Storage Base Cabinets have a steel reinforced polyethylene lining, a full depth adjustable shelf and louvered doors for ventilation.

Flammable Storage Base Cabinets are constructed in accordance with OSHA and NFPA requirements. They feature double wall construction, panned bottom, full depth expanded metal shelf, and a lockable three point door latch. Flammable storage cabinets are 18" deep.

Filler Panels are required to close off the pipe chase at the exposed end(s) of the base cabinet. Each filler panel comes complete with clips, slip joint and hardware.

Standard Base Cabinet

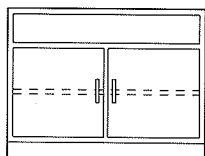

- B3535-20P 35"
- B3536-20P 36"
- B3547-20P 47"
- B3548-20P 48"
- B3558-20P 58"
- B3560-20P 60"

Acid Storage Base Cabinet

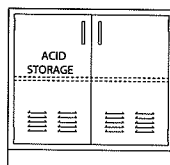

- ASB3535-20P18 35"
- ASB3536-20P18 36"
- ASB3547-20P18 47"
- ASB3548-20P18 48"

Flammable Storage Base Cabinet

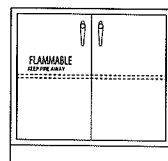

- FSB3535-20018 35"
- FSB3536-20018 36"
- FSB3547-20018 47"
- FSB3548-20018 48"

End Filler Panels

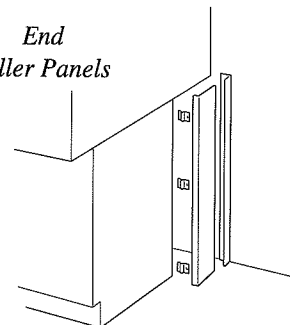

- LF35-7 7"
- LF35-11 11"

### Sash Options

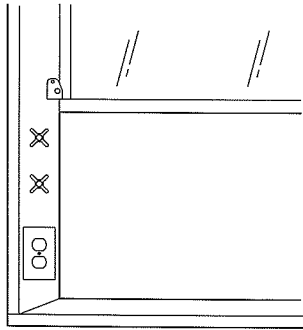

#### Sash Stop

Limiting the sash opening of a Fume Hood can greatly reduce the amount of air required to achieve a required face velocity.

B-780 Sash Stop limits the vertical rising of the sash by 50%. A manual override allows you to fully open the sash for setups or cleaning. The Sash Stop re-engages as the sash is lowered below it.

#### Horizontal/Vertical Sash

Combination Horizontal/Vertical Sash provides both safety and energy efficiency. The horizontal sliding panels act as a safety shield while reducing the Sash opening by 50%. 47"/48" and 58"/60" models have two panels and 70"/72", 82"/84" and 94"/96" have four panels.

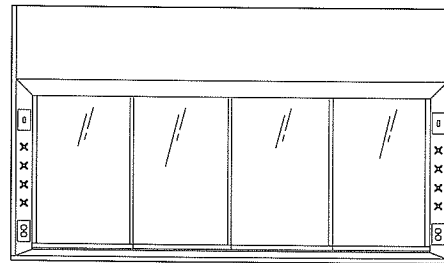

47"	B-7810
48"	B-1781
58"	B-7820
60"	B-1782
70"	B-7830
72"	B-1783
82"	B-7840
84"	B-1784
94"	B-7850
96"	B-1785

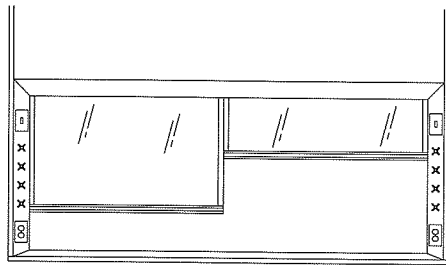

70"	B-7860
72"	B-1786
82"	B-7870
84"	B-1787
94"	B-7880
96"	B-1788

#### Postless Double Vertical Rising

The Double Vertical Rising Sash has two independently operating steel framed sashes. Each Sash has its own counterweight for one finger operation.

### Fume Hood Ceiling Enclosures

Ceiling Enclosures are designed to be mounted on top of a Fume Hood and extend up through a drop-in ceiling. A front access panel provides for relamping of the hood.

For use with ceiling heights from 102" to 108" only. Special sizes are also available.

For Airfoil Add Air Fume Hoods add the suffix -AA to the part number.

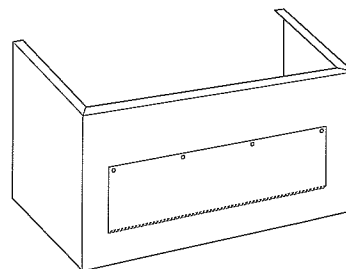

47"	B-794
48"	B-1794
58"	B-795
60"	B-1795
70"	B-796
72"	B-1796
82"	B-797
84"	B-1797
94"	B-798
96"	B-1798

### Remote Control Fume Hood Fixtures

Remote control valves have forged brass valve bodies for strength and durability. Valves for gas, air, vacuum and special gases are of needle type design with a stainless steel floating cone and stainless steel replaceable seat. Valves for steam service have a flat Teflon valve disc and stainless steel replaceable seat; valves for water service have a renewable unit including a stainless steel seat and volume control. All outlet assemblies for gases are furnished as nylon plastic, and polished chrome plated for water. For acid and solvent resistant coating, add the following suffix to part numbers, which will also change the nylon items to brass.

Clear Epoxy	01
White Epoxy	02
Black Epoxy	03
Sepia Bronze	04
Metallic Aluminum	05

For factory setting of a service fixture, specify part number F-330 in addition to the service fixture number.

For factory setting and piping of service fixtures, specify part number F-300 in addition to the service fixture number.

F-100 - Remote service valve with angled hose cock outlet. For use with gas, air, vacuum, steam or other special gases. Specify type of service.

F-110 - Remote service valve with gooseneck, for use with water; specify hot or cold water.

F-120 - Remote service valve with gooseneck and vacuum breaker, for use with water; specify hot or cold water.

F-125 - Dual remote service valve with gooseneck, for use with hot and cold water.

F-130 - Dual remote service valve with gooseneck and vacuum breaker, for use with hot and cold water.

### Air Velocity Monitor & Alarm

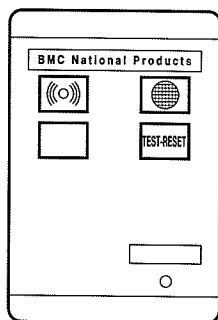

F-278

F-278 Velocity Monitor measures the face velocity of the Fume Hood. The monitor includes a visual safe indicator light, visual alarm indicator light, audible alarm and a test reset button which also manually silences the alarm. Field calibration requires the use of an optional air flow measuring device as shown on page 32.

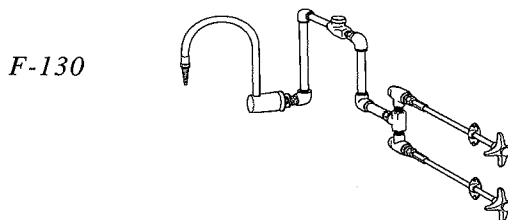
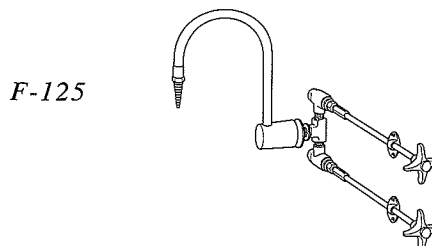
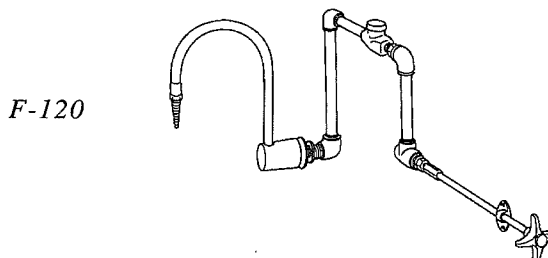
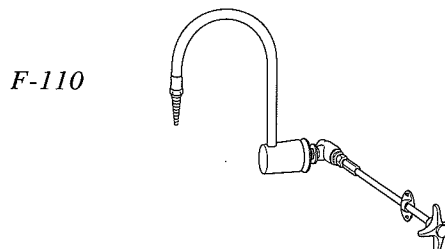
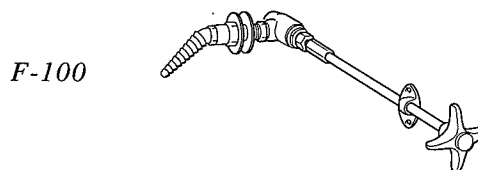

## Electrical Services

Flush mount electrical service fixtures come complete with device box and stainless steel face plate.

Explosion proof fixtures meet Class 1, Group C & D requirements. Explosion proof outlets and switches must be mounted on the front panel of the base cabinet or the exterior side of the Fume Hood.

For factory setting of electrical fixtures, specify part number F-340 in addition to the electrical fixture number.

For factory setting and wiring of electrical fixtures, specify part number F-320 in addition to the electrical fixture number.

Factory wiring of explosion proof fixtures on application only.

F-200 - Single pole light switch, 115 volt, 15 amp.

F-210 - Manual motor starter switch with pilot light, 115 volt, 15 amp. Heating element not included.

F-220 - Duplex receptacle, 115 volt, 15 amp.

F-221 - Duplex receptacle, 115 volt, 20 amp.

F-225 - GFI duplex receptacle, 115 volt, 15 amp.

F-260 - Explosion proof light fixture, specify two fixtures on hoods 84" and over.

F-262 - Explosion proof receptacle.

F-264 - Explosion proof switch.

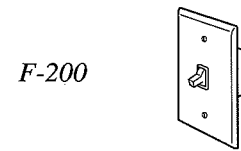

F-210

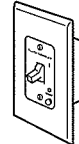

F-220  
F-221



F-225

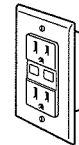

F-260

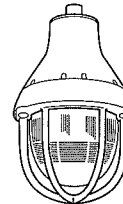

F-262

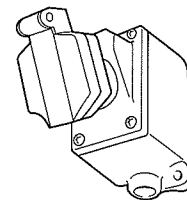

F-264

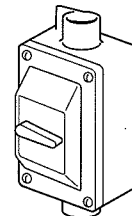

## Countertops

B-804	47"
B-8040	48"
B-805	58"
B-8050	60"
B-806	70"
B-8060	72"
B-807	82"
B-8070	84"
B-808	94"
B-8080	96"

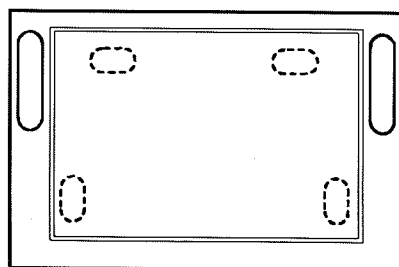

Front

Fume Hood work surfaces are molded from a modified epoxy resin that has been specially compounded and cured to provide optimum physical and chemical resistance required for a heavy duty laboratory working surface. Countertops are 1" thick with a 3/8" deep dishing to contain spills and have a non-glaring black finish.

If sinks or cupsinks are required, specify location.

### Sinks

Sinks are available in a variety of sizes and configurations for installation in Fume Hoods.

F-400 - Oval epoxy resin cupsink, 3"x6", 1 1/2" NPT outlet connection.

F-401 - Oval polypropylene panel mount cupsink, 3"x6", with retainer nut, 1 1/2" NPT outlet connection.

F-402 - Rectangular epoxy resin cupsink, 13 3/4" x 4 1/2" x 5 1/2" with stainless steel straining screen, 1 1/2" NPT outlet.

F-410 - Drop-in epoxy resin sink, 16" x 12" x 8" Dp.

F-411 - Drop-in epoxy resin sink, 18" x 15" x 8" Dp.

F-412 - Drop-in epoxy resin sink, 24" x 16" x 8" Dp.

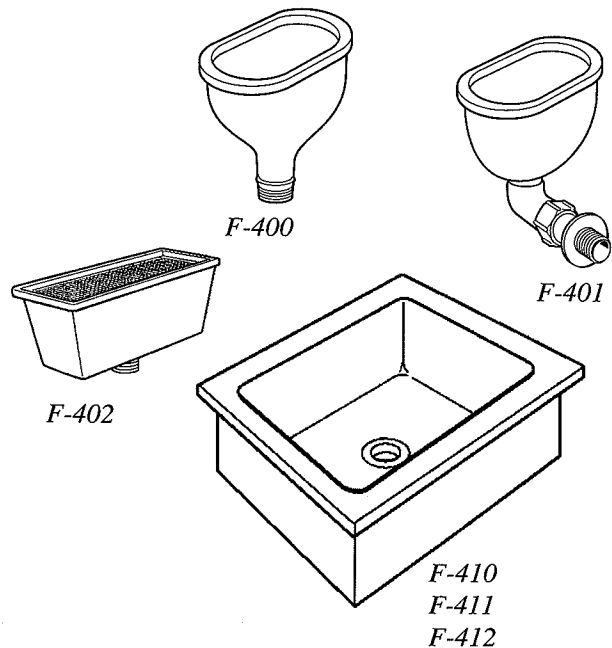

### Drains and Traps

F-420 - Poly resin sink outlet with retainer nut, 1 1/2" NPT outlet connection.

F-425 - Polypropylene p-trap with adjustable riser, 1 1/2" NPT outlet connection.

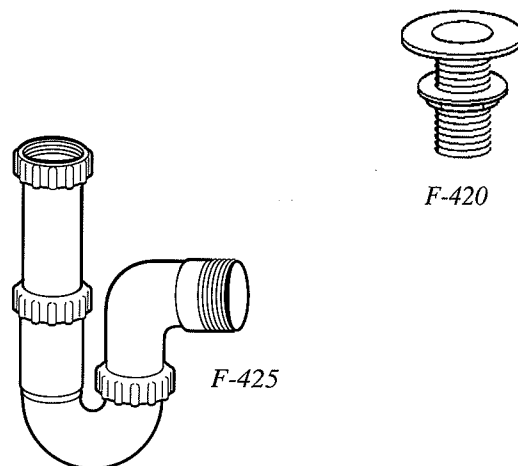

### Baths

Baths are available in steam, hot water or electric. Each bath is furnished with four sets of concentric rings which are spaced on 1" increments up to 6" diameter. Baths are constructed of 20 gauge, type 304 stainless steel and come complete with a remote valve for mounting in the post of the Fume Hood. Size is 18" x 18".

- F-430 Steam
- F-431 Hot Water
- F-432 Electric

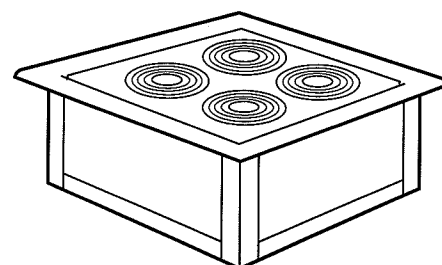

Baths

## Fire Extinguishers

F-439 Automatic Fire Extinguisher units are available for installation in Fume Hoods. Fire Extinguishers are activated by a fusible link. The link melts at 165° F, opening the valve which releases a multipurpose ABC Dry Chemical. Cylinders are constructed of stainless steel and come complete with mounting bracket. Fume Hoods 70" and wider require the use of two Fire Extinguishers for adequate projection.

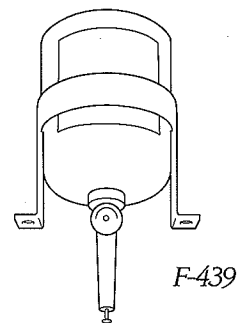

## Vent Kits

F-440 Vent Kits are used to vent acid or flammable storage cabinets to the Fume Hood.

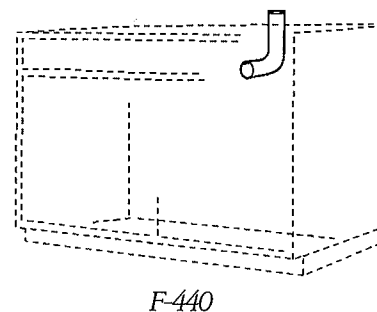

## Baffle Options

*Standard Fume Hoods are equipped with an adjustable upper baffle only. Other adjustable baffle options are available as follows:*

- B-790 Lower Adjustable Baffle
- B-791 Single Point Remote Adjustable Baffle for 47"/48", 58"/60 and 70"/72" Hoods.
- B-792 Single Point Remote Adjustable Baffle for 82"/84" and 94"/96" Hoods.

## Material Options

*The design of the PRIME-AIRE™ Fume Hoods allows for easy substitution of standard components with optional materials.*

Interior linings are available in minerit, PVC or stainless steel in lieu of our standard Resin-Chem.

Sash options include full framed, painted or stainless steel sash.

Sash tracks and lower airfoils are both available in stainless steel.

Contact your **PRIME-AIRE™** representative to assist you in specifying these items.



## Lattice Assemblies

Lattice assemblies consist of the components listed below and can be configured as required. Lattice rods come in standard length and can be cut in the field for an exact fit.

- F-441 36" x 1/2" DIA. ROD
- F-442 48" x 1/2" DIA. ROD
- F-443 72" x 1/2" DIA. ROD
- F-444 96" x 1/2" DIA. ROD
- F-445 CLAMP FOR 1/2" DIA. ROD
- F-446 FOOT FOR 1/2" DIA. ROD

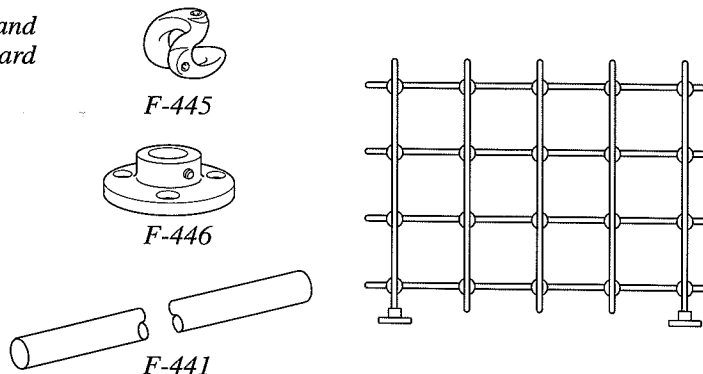

## Anemometer

F-422 Hand held, rotating vane anemometer is ideal for monitoring Fume Hood face velocity. The unit which is completely self-contained is powered by a 9-volt battery and can be operated with one hand.

Operation is simple, with a single push-button control in the handle. When the button is depressed and held the unit will display a digital read-out of the Fume Hood face velocity.

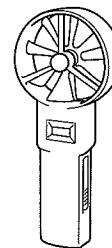

F-422

## Smoke

A variety of smoke generating devices are available to monitor the airflow into and around the Fume Hood.

F-415 Smoke sticks generate 2-3 minutes of continuous smoke and come in packages of 12.

F-416 Smoke bottle contains an ampule that, when broken, releases a dense white smoke.

F-417 Smoke cartridges generate 45 seconds of continuous smoke and come in packages of 10.

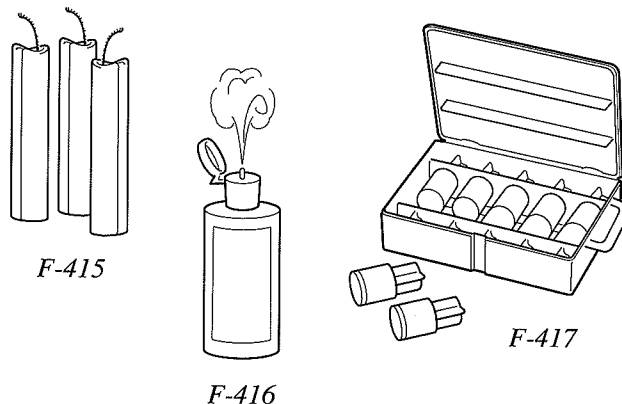

F-415

F-416

F-417

## Filters

Exhaust filters are used to entrap and retain airborne particles of contamination at their source of origin, preventing the spread of contamination through the ductwork and through the point of discharge.

Note: not recommended for use with radioisotopes

Filter housing assemblies consist of a stainless steel enclosure with a removable face panel that permits installation of the pre-filter and HEPA filter.

F-423 Filter housing measures 25 13/16" x 23 7/8" x 24 3/8" and includes a 24" x 24" x 11 1/2" HEPA filter and pre-filter. Collar size is 10" Diameter.

F-424 Filter housing measures 31 13/16" x 30 3/8" x 24 3/8" and includes a 24" x 30" x 11 1/2" HEPA filter and pre-filter. Collar size is 12" Diameter.

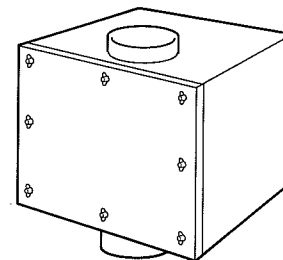

F-423

F-424

## Duct Transitions

Duct Transitions are designed to convert the rectangular collar of the PRIME-AIRE™ Fume Hood to a round collar.

Transitions are constructed of heavy gage coated steel and will work with standard round ductwork.

- F-500 6"x12" Collar to 9" Dia.
- F-501 6"x12" Collar to 10" Dia.
- F-502 6"x14" Collar to 9" Dia.
- F-503 6"x16" Collar to 10" Dia.
- F-504 6"x20" Collar to 12" Dia.

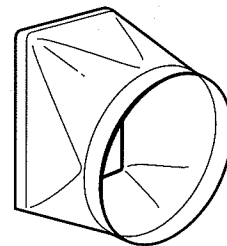

Transitions

## Y Branches

Y Branches are used to connect two exhaust or supply ducts on Fume Hoods that require more than one exhaust or supply collar. Branches are constructed of coated steel and will work with standard round ductwork.

- F-506 (2) 9" Dia. to a Single 12" Dia.
- F-507 (2) 9" Dia. to a Single 14" Dia.

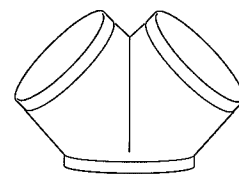

Y-Branches

## Duct Wash Down

F-508 Wash Down assemblies are suited for use with perchloric acid duct systems. Each nozzle is capable of delivering 3 gallons of water per minute at a water pressure of 40 PSI. The Wash Down assembly is designed to be attached to 12" dia. duct and has a 1/4" male pipe connection.

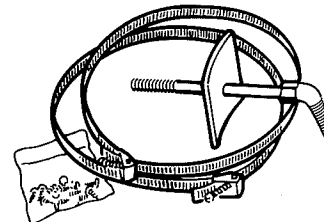

F-508

## Local Exhaust

F-509 The PRIME-AIRE™ Local Exhaust Hood is designed for use with atomic absorption spectrophotometers or flame photometer equipment. Unit comes complete with a 12" dia. stainless steel cone, 8' of 6" dia. flexible duct and adjustable support arm.

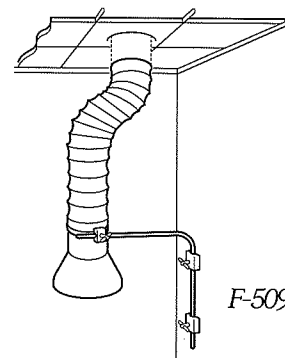

F-509

## Blowers

Blowers for both exhaust and supply are designed for efficient, quiet, continuous duty. Units have a forward curved impeller and come complete with a weatherproof drive cover. Spark resistant and corrosion resistant coatings are available upon request.

When using the chart on page 34, figure the equivalent of 15 linear feet of ductwork for each 90 degree elbow. For complex exhaust systems, contact your PRIME-AIRE™ representative for assistance in selecting a blower.

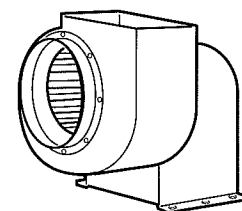

## Blowers

HOOD MODEL NO.	VELOCITY FPM	VOLUME CFM	DUCT DIA	0-25 L/F OF DUCT		25-50 L/F OF DUCT		50-75 L/F OF DUCT		75-100 L/F OF DUCT	
				BLOWER	RPM	BLOWER	RPM	BLOWER	RPM	BLOWER	RPM
<b>AIRFOIL BYPASS FUME HOODS</b>											
B-704/B-604	100	844/867	9"	9B	1016	9B	1144	9C	1203	9D	1281
B-705/B-605	100	1089/1133	10"	11C	882	11D	981	11D	1026	11D	1071
B-706/B-606	100	1355/1400	12"	12C	686	12D	733	12D	822	12D	865
B-707/B-607	100	1616/1667	12"	12D	725	12D	747	12D	788	12D	829
B-708/B-608	100	1889/1933	14"	15D	565	15D	565	15D	603	15D	603
<b>AIRFOIL ADD AIR FUME HOODS</b>											
B-724/B-624	100	844/867	9"	9B	1016	9B	1144	9C	1203	9D	1261
	SUPPLY	590/607	9"	9A	813	9A	880	9A	897	9A	974
B-725/B-625	100	1089/1133	10"	11C	882	11D	981	11D	1026	11D	1071
	SUPPLY	762/793	10"	11A	693	11A	750	11A	757	11A	822
B-726/B-626	100	1355/1400	12"	12C	686	12D	733	12D	822	12D	865
	SUPPLY	948/980	12"	12A	545	12A	560	12A	608	12A	668
B-727/B-627	100	1616/1667	12"	12E	747	12E	788	12E	868	12E	906
	SUPPLY	1131/1167	12"	12B	580	12B	625	12B	650	12B	677
B-728/B-628	100	1889/1933	14"	15D	565	15D	565	15D	603	15D	603
	SUPPLY	1322/1353	14"	13C	575	13C	596	13C	640	13C	685
<b>AIRFOIL ADA FUME HOODS</b>											
B-684	100	433	9"	8A	950	8A	985	8A	1020	8A	1055
B-785/B-685	100	588/567	10"	8A	1126	8A	1126	8A	1126	8A	1126
B-786/B-686	100	738/700	12"	9A	826	9A	826	9A	826	9A	826
B-787/B-687	100	888/833	12"	11A	674	11A	674	11A	674	11A	746
B-788/B-688	100	1038/967	14"	9C	1064	9C	1064	9C	1064	9C	1064
<b>AIRFOIL RADIO ISOTOPE AIR FUME HOODS</b>											
B-734/B-634	125	1055/1083	9"	9D	1296	9D	1349	9D	1449	9E	1543
B-735/B-635	125	1361/1417	10"	11E	1155	11E	1195	11E	1267	11E	1337
B-736/B-636	125	1694/1750	12"	12E	848	12E	886	12E	823	12E	923
B-737/B-637	125	2020/2083	12"	13F	821	13F	876	13F	933	13F	990
B-738/B-638	125	2361/2417	14"	15E	671	15E	703	15F	766	15F	766
<b>AIRFOIL PERCHLORIC ACID FUME HOODS</b>											
B-744/B-644	150	1266/1300	9"	GFE-12D	2200	GFE-12D	2200	GFE-12D	2382	GFE-12E	2382
B-745/B-645	150	1634/1700	10"	GFE-12D	2570	GFE-12E	2570	GFE-12F	2732	GFE-12F	2732
B-746/B-646	150	2033/2100	12"	GFE-12F	2728	GFE-12F	2886	GFE-12F	2886	GFE-12G	2886
B-747/B-647	150	2492/2500	12"	GFE-15H	2259	GFE-15H	2396	GFE-15I	2522	GFE-15I	2637
B-748/B-648	150	2834/2900	14"	GFE-15H	2431	GFE-15I	2557	GFE-15I	2557	GFE-15I	2600
<b>AIRFOIL LOW BENCH FUME HOODS</b>											
B-756/B-656	100	1078/1107	10"	11C	880	11D	979	11D	1020	11D	1068
B-758/B-658	100	1509/1529	12"	12D	700	12D	769	12D	851	12E	900
<b>AIRFOIL WALK-IN FUME HOODS</b>											
B-766/B-666	100	1408/1575	12"	12C	705	12D	740	12D	794	12D	877
B-768/B-668	100	1964/2175	14"	15D	570	12D	614	15E	649	15E	680
<b>THIN WALL FUME HOODS</b>											
B-824/B-834	100	926/947	9"	9C	1078	9C	1078	9C	1078	9C	1078
B-825/B-835	100	1163/1206	10"	11D	1033	11D	1076	11E	1117	11E	1150
B-826/B-836	100	1421/1464	12"	12D	836	12E	877	12E	895	12E	915
B-827/B-837	100	1679/1722	12"	12E	809	12E	888	12F	886	12F	923
B-828/B-838	100	1938/1981	14"	15D	570	15D	611	15E	645	15E	652
<b>DEMONSTRATION FUME HOODS</b>											
B-814	100	758	10"	11A	750	11A	764	11A	791	11A	822
B-815/B-816	100	972/992	10"	11C	870	11C	870	11C	870	11C	870
<b>CANOPY FUME HOODS</b>											
B-773/B-7730	50	947/963	12"	12A	479	12A	501	12A	523	12A	545
B-774/B-7740	50	1122/1138	12"	12B	580	12B	625	12B	650	12B	677
B-766/B-7760	50	1458/1502	12"	12D	705	12D	750	12D	836	12D	877

FAN SIZE	INLET	OUTLET
9	9" DIA. OD	10 3/4" X 6 1/2" O.D.
11	10" DIA. OD	11 3/4" X 8" O.D.
12	13 1/4" DIA. OD	13 1/4" X 9 5/8" O.D.
13	14 1/2" DIA. OD	14 5/8" X 10 3/4" O.D.
15	16 1/8" DIA. OD	16 1/4" X 11 3/4" O.D.
GFE-12*	12 1/2" DIA. ID**	13 1/2" X 18 1/8" O.D.**
GFE-15*	15 1/2" DIA. ID**	15 1/2" X 21 1/4" O.D.**

ELEC. REQUIREMENTS	HORSEPOWER	VOLTAGE
A	1/6	115/230, 1PH
B	1/4	115/230, 1PH
C	1/3	115/230, 1PH
D	1/2	115/230, 1PH
E	3/4	200/208/460, 3PH
F	1	200/208/460, 3PH
G	1 1/4	200/208/460, 3PH
H	1 3/4	200/208/460, 3PH
I	2	200/208/460, 3PH

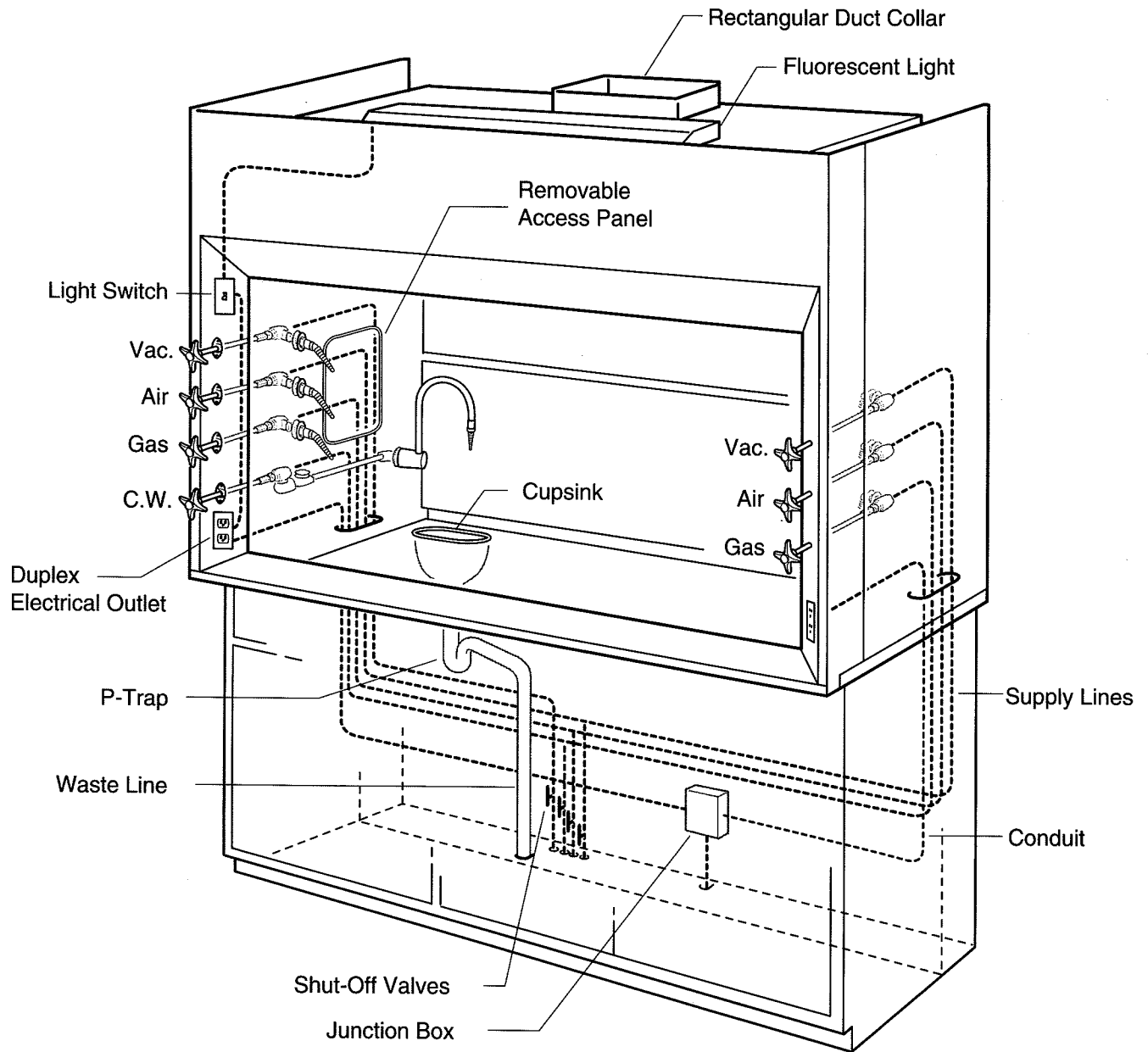

The above illustration depicts the routing of service and electrical lines in a typical Fume Hood. Unless specified otherwise, all service and electrical fixtures are shipped separately for installation in the field. Piping, conduit and wire are not included and must be furnished by others in accordance with local codes.

The exact routing of service lines will vary depending on the point of origin and number of services. The illustration shown above shows the service lines feeding up through the Hood from the floor. Service lines can also be routed through the Fume Hood side wall from the ceiling.

## PRIME-AIRE™ Fume Hood Specifications

### General

**PRIME-AIRE™** Fume Hoods shall be of a "picture frame" air foil design and construction. Each Fume Hood superstructure shall provide for safe efficient removal of all fumes, both heavy and light, with the least amount of turbulence as the air enters the Hood.

Standard airfoil bench Hood superstructures are tested in accordance with the current ASHRAE Test Procedure and perform well within the American Conference of Governmental Industrial Hygienists recommendations.

### Material

**Metal:** Prime furniture steel, free of scales, buckles, or other defects; ASTM A366.

**Stainless Steel:** Type 304 or 316, as noted, commercial grade. No. 4 Finish, ASTM A167.

**Safety Glass:** 7/32" Laminated; conforming to ANSI Z97.1 for 400-foot-pound impact, and to CPSC 16 CFR 1201 for Category II Safety Glazing.

**PVC:** Extruded Black PVC.

**Resin-Chem:** White chemical resistant, fiberglass reinforced thermoset resin sheet.

### Construction

Fume Hood superstructures have a double wall construction consisting of an outer shell of sheet steel and an inner liner of corrosion resistant material as specified. Attachment of the interior lining material to the steel framing members is made with non-metallic fasteners. The double wall shall house and conceal steel framing members, attaching brackets and remote operating service fixture valves.

The exterior side panels of the superstructure are constructed of 18 gage steel and are removable for access into the interior housing. Access may also be gained through removable panels in the interior liner.

Each superstructure shall have an internal baffle system of the same material as the interior liner. This baffle system shall provide for safe efficient removal of fumes when the superstructure is connected to a properly installed exhaust system. A manual adjustment is provided on the upper part of the baffle to allow the operator to set the Fume Hood for

heavy or light fumes. All baffles are removable for cleaning.

Unless specified for use in a variable air volume (VAV) system, the superstructures shall be provided with an air bypass feature. The bypass, located at the upper front interior of the Hood, shall open as the sash is lowered, providing for a relatively constant exhaust volume of the Fume Hood superstructure

When specified, the upper front exterior panel of the superstructure can be furnished with louvers. The louvers provide for proper operation of the bypass feature when the top of the superstructure is closed off to the ceiling.

A two tube, rapid start, vapor sealed fluorescent light fixture of maximum length shall be provided on each superstructure. Each fixture shall include two soft white fluorescent tubes. Light fixtures are relamped from the top front of the superstructure.

Exhaust outlets shall be rectangular, 18 gage stainless steel. Hoods with stainless steel interior liners shall have 18 gage stainless steel exhaust collars welded in place.

Fume Hoods shall have a full view, vertical rising, laminated safety glass sash framed with a solid black PVC edging. The sash shall have a full width finger lift with a 16 gage internal support tube. The sash shall not require the use of a center mullion. Sash guides shall be extruded, black PVC.

The sash shall be counterbalanced with a single weight located in the center rear of the superstructure. Two 1/8" diameter stainless steel cables connect the sash to the weight. The use of two cables acts as a safety mechanism keeping the sash from falling in the event that one cable would fail. The cables ride on 2" diameter nylon ball bearing pulleys. The cable/pulley assembly shall have an adjustment located on the top of the superstructure for proper alignment of the sash.

A lower airfoil of 14 gage steel, coated with a black baked-on chemical resistant finish, shall act as the sash stop. In addition, the airfoil shall provide a 1" space between the bottom of the sash, in the closed position, and the work surface. This 1" space shall provide for a continuous sweep of fumes from the work surface.

## **Airfoil Bypass Fume Hoods**

Constructed as specified above. The Airfoil Bypass Fume Hood superstructure has a white Resin-Chem interior lining.

## **Airfoil Add Air Fume Hoods**

The Add Air superstructure shall have an 18 gage, painted steel add air plenum. The plenum shall be capable of properly distributing up to 70% of the air requirements of the Hood. The add air plenum shall be of standard size and can be added to any of the standard **PRIME-AIRE™** Fume Hoods.

The interior lining of the Airfoil Add Air Fume Hood superstructure shall be white Resin-Chem.

## **Airfoil Radio Isotope Hoods**

The interior lining and work surface of the Radio Isotope superstructure shall be type 304 stainless steel. Seams and joints present in the interior and work surface shall be welded to eliminate pockets, cracks and crevices that would permit a buildup of radioactive materials.

The work surface shall be an integral welded part of the superstructure. It shall be watertight and furnished with a raised edge to contain spills. It shall be properly reinforced to support 200 lbs. per square foot up to a total weight of 1,000 lbs. per Hood or base cabinet section.

An 18 gage type 304 stainless steel frame shall encase the laminated safety glass sash. The vertical sliding sash shall ride in type 304 stainless steel sash guides.

Interior removable access panels are provided for access to the interior housing.

All other features of the Hood are as specified under "Construction."

## **Airfoil Perchloric Acid Fume Hoods**

Perchloric Acid Fume Hood superstructures shall be identified by a label indicating suitability for use with perchloric acid procedures. All exposed parts of the superstructure interior shall be seamless welded coved cornered, type 316, stainless steel.

The work surface shall be an integral welded part of the superstructure. It shall be watertight and furnished with a raised edge to contain spills. A full width drain through shall be located below the baffle.

A water spray (wash down system) shall be provided for rinsing the area behind the baffle. Service fitting controls for the wash down system shall be external to the Hood, clearly identified and within easy reach.

An 18 gage, type 316 stainless steel frame shall encase the laminated safety glass sash. The vertical sliding sash shall ride in type 316, stainless steel sash guides.

Interior removable access panels are not provided on Perchloric Acid superstructures.

All other features of the Hood are as specified under "Construction."

## **Low Bench Hoods**

Low Bench Fume Hood superstructures shall have a white Resin-Chem interior lining. The sash shall consist of four horizontal sliding, laminated safety glass panels, with a stainless steel edge trim. The panels shall ride on two tracks of extruded aluminum.

Two removable interior panels shall be located on each side of the Fume Hood superstructure.

All other fixtures of the Low Bench Fume Hood superstructure are specified under "Construction."

## **Walk-In Fume Hoods**

Walk-In Fume Hood superstructures shall have a white Resin-Chem interior lining. The sash shall consist of two vertical sliding, laminated safety glass panels as specified under "Construction."

Two removable interior access panels shall be located on each side of the Fume Hood superstructure.

All other features of the Walk-In Fume Hood superstructure are as specified under "Construction."

**Add Air** - Supply air delivered to a laboratory Fume Hood to reduce room air consumption..

**Air Foil** - Curved or angular members at the Fume Hood entrance.

**Air Volume** - Quantity of air normally expressed in cubic feet per minute (CFM).

**ASHRAE** - American Society of Heating, Refrigerating and Air Conditioning Engineers.

**Baffle** - Panel located across the Fume Hood interior back which controls the pattern of air moving into and through the Fume Hood.

**Blower** - Air moving device, sometimes called a fan, consisting of a motor, impeller and housing.

**Bypass** - Compensating opening that maintains a relatively constant volume exhaust through a Fume Hood regardless of sash position and that functions to limit the maximum face velocity as the sash is lowered.

**Canopy Hood** - Suspended ventilating device for non-critical use to exhaust only heat, water vapor and odors.

**Countertop** - Work surface resting on a base cabinet.

**Duct** - Round, square or rectangular tube used to enclose moving air.

**Duct Velocity** - Speed of air moving in a duct, usually expressed in feet per minute (FPM).

**Exhaust Collar** - Connection between exhaust duct and Fume Hood through which all exhaust air passes.

**Face Velocity** - Speed of air moving into Fume Hood entrance or access opening, expressed in feet per minute (FPM).

**Liner** - Interior lining used for side, back, top enclosure panels, exhaust plenum and baffle system of a laboratory Fume Hood.

**Lintel** - Portion of laboratory Fume Hood front located directly above the access opening.

**Resin-Chem** - White chemical resistant fiberglass reinforced thermoset resin sheet.

**Sash** - Movable transparent panel set in Fume Hood entrance.

**Service Fitting** - Fixture laboratory plumbing mounted on the Fume Hood intended to control the supply of piped gases and liquids for laboratory use.

**Static Pressure** - Air pressure in laboratory Fume Hood or duct, usually expressed in inches of water.

**Static Pressure Loss** - Measurement of resistance created when air moves through a duct or hood, usually expressed in inches of water.

**Superstructure** - That portion of a laboratory Fume Hood that is supported by the countertop.

NOTES:



NOTES:



## ***PRIME-AIRE***

**PRIME Industries, Inc.**  
2600 Warrenville Rd., Suite 205  
Downers Grove, IL 60515  
Telephone: (630) 725-9200  
Fax: (630) 725-9201  
Toll Free: (800) 203-4920  
[www.piilab.com](http://www.piilab.com)

**PRIME-AIRE BY PRIME,  
2005 Printed in the U.S.A.**